

Developers and Manufacturers of Hydraulic Flanges & Components

SCHEDULE 80 BUTT WELD IN-LINE PIPE FLANGES

ISO 6162-1 PATTERN / J518 61 SERIES METRIC

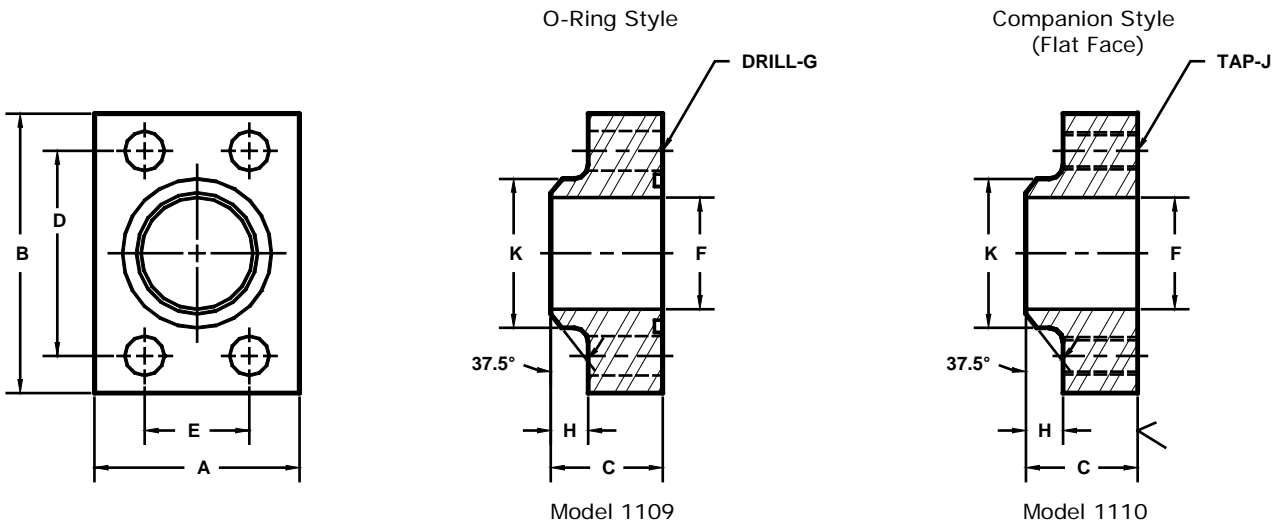

FLANGE SIZE	PIPE SIZE	PART NUMBER	A	B	C	D	E	F	G	H	J	K	MOUNTING KIT ^①		
													PART NO.	BOLT SIZE	O-RING
13	1/2	1109-08-08M8	38.0	54.0	31.5	38.10 (1.500)	17.48 (.688)	13.5	8.5	9.7	----	22.4	MKM 512	M8 x 35	210
		1110-08-08M8									----		----	----	
19	3/4	1109-12-08M10	44.5	66.5	31.5	47.63 (1.875)	22.23 (.875)	13.5	10.5	9.7	----	22.4	MKM 1525	M10 x 35	214
		1110-12-08M10									----		----	----	
19	3/4	1109-12-12M10	44.5	66.5	31.5	47.63 (1.875)	22.23 (.875)	19.0	10.5	9.7	----	28.4	MKM 1525	M10 x 35	214
		1110-12-12M10									----		----	----	
25	1	1109-16-12M10	51.0	71.5	31.5	52.37 (2.062)	26.19 (1.031)	19.0	10.5	9.7	----	28.4	MKM 1542	M10 x 35	219
		1110-16-12M10									----		----	----	
25	1	1109-16-16M10	51.0	71.5	31.5	52.37 (2.062)	26.19 (1.031)	23.8	10.5	9.7	----	35.1	MKM 1542	M10 x 35	219
		1110-16-16M10									----		----	----	
32	1 1/4	1109-20-16M10	63.5	81.0	31.5	58.72 (2.312)	30.18 (1.188)	23.8	10.5	9.7	----	35.1	MKM 4520	M10 x 35	222
		1110-20-16M10									----		----	----	
32	1 1/4	1109-20-16M12*	63.5	81.0	31.5	58.72 (2.312)	30.18 (1.188)	23.8	12.5	9.7	----	35.1	MKM 1527	M12 x 40	222
		1110-20-16M12*									----		----	----	
32	1 1/4	1109-20-20M10	63.5	81.0	31.5	58.72 (2.312)	30.18 (1.188)	31.5	10.5	9.7	----	44.5	MKM 4520	M10 x 35	222
		1110-20-20M10									----		----	----	
32	1 1/4	1109-20-20M12*	63.5	81.0	31.5	58.72 (2.312)	30.18 (1.188)	31.5	12.5	9.7	----	44.5	MKM 1527	M12 x 40	222
		1110-20-20M12*									----		----	----	
38	1 1/2	1109-24-20M12	70.0	95.5	38.0	69.85 (2.750)	35.71 (1.406)	31.5	13.0	12.7	----	44.5	MKM 4551	M12 x 40	225
		1110-24-20M12									----		----	----	
38	1 1/2	1109-24-20M14*	70.0	95.5	38.0	69.85 (2.750)	35.71 (1.406)	31.5	15.0	12.7	----	44.5	MKM 1547	M14 x 45	225
		1110-24-20M14*									----		----	----	
38	1 1/2	1109-24-24M12	70.0	95.5	38.0	69.85 (2.750)	35.71 (1.406)	38.0	13.0	12.7	----	50.8	MKM 4551	M12 x 40	225
		1110-24-24M12									----		----	----	
38	1 1/2	1109-24-24M14*	70.0	95.5	38.0	69.85 (2.750)	35.71 (1.406)	38.0	15.0	12.7	----	50.8	MKM 1547	M14 x 45	225
		1110-24-24M14*									----		----	----	

① Order Separately

* Non Standard Bolt For This Flange Size.

MATERIAL : STEEL
1/07

NOTE: DIMENSIONS ARE IN MILLIMETERS. INCH EQUIVALENTS IN ().

Developers and Manufacturers of Hydraulic Flanges & Components

SCHEDULE 80 BUTT WELD IN-LINE PIPE FLANGES

ISO 6162-1 PATTERN / J518 61 SERIES METRIC

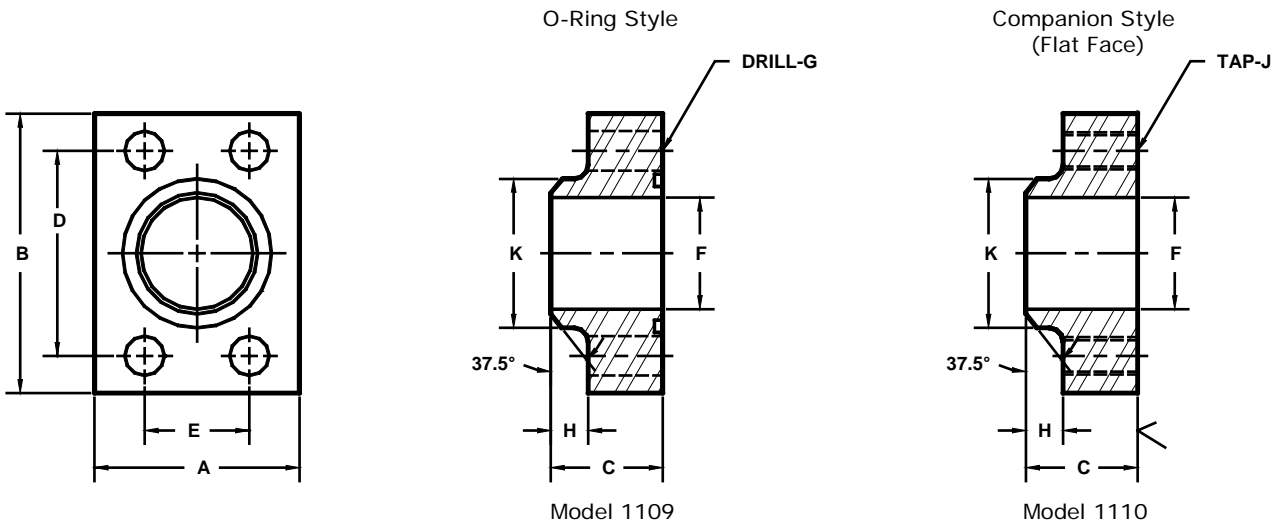

FLANGE SIZE	PIPE SIZE	PART NUMBER	A	B	C	D	E	F	G	H	J	K	MOUNTING KIT ^①		
													PART NO.	BOLT SIZE	O-RING
51	2	1109-32-24M12	82.5	101.5	38.0	77.77 (3.062)	42.88 (1.688)	38.0	13.0	12.7	----	50.8	MKM 4552	M12 x 45	228
		1110-32-24M12									M12 x 1.75		-----	---	
51	2	1109-32-24M14*	82.5	101.5	38.0	77.77 (3.062)	42.88 (1.688)	38.0	15.0	12.7	----	50.8	MKM 582	M14 x 45	228
		1110-32-24M14*									M14 x 2		-----	---	
51	2	1109-32-32M12	82.5	101.5	38.0	77.77 (3.062)	42.88 (1.688)	49.2	13.0	12.7	----	63.5	MKM 4552	M12 x 45	228
		1110-32-32M12									M12 x 1.75		-----	---	
51	2	1109-32-32M14*	82.5	101.5	38.0	77.77 (3.062)	42.88 (1.688)	49.2	15.0	12.7	----	63.5	MKM 582	M14 x 45	228
		1110-32-32M14*									M14 x 2		-----	---	
64 ^②	2½	1109-40-40M12	101.5	114.0	44.0	88.90 (3.500)	50.80 (2.000)	59.0	13.0	12.7	----	76.2	MKM 2575	M12 x 50	232
		1110-40-40M12									M12 x 1.75		-----	---	
64 ^②	2½	1109-40-40M14*	101.5	114.0	44.0	88.90 (3.500)	50.80 (2.000)	59.0	15.0	12.7	----	76.2	MKM 561	M14 x 50	232
		1110-40-40M14*									M14 x 2		-----	---	
76 ^③	3	1109-48-32M16	114.0	135.0	50.5	106.38 (4.188)	61.93 (2.438)	49.2	17.0	12.7	----	63.5	MKM 585	M16 x 60	237
		1110-48-32M16									M16 x 2		-----	---	
76 ^③	3	1109-48-40M16	114.0	135.0	50.5	106.38 (4.188)	61.93 (2.438)	59.0	17.0	12.7	----	76.2	MKM 585	M16 x 60	237
		1110-48-40M16									M16 x 2		-----	---	
76 ^③	3	1109-48-48M16	114.0	135.0	50.5	106.38 (4.188)	61.93 (2.438)	73.6	17.0	12.7	----	88.9	MKM 585	M16 x 60	237
		1110-48-48M16									M16 x 2		-----	---	
89 ^④	3½	1109-56-48M16	127.0	152.5	38.0	120.65 (4.750)	69.85 (2.750)	73.6	17.0	12.7	----	88.9	MKM 1571	M16 x 50	241
		1110-56-48M16									M16 x 2		-----	---	
89 ^④	3½	1109-56-56M16	127.0	152.5	38.0	120.65 (4.750)	69.85 (2.750)	85.3	17.0	12.7	----	101.5	MKM 1571	M16 x 50	241
		1110-56-56M16									M16 x 2		-----	---	
102 ^④	4	1109-64-48M16	139.5	162.0	38.0	130.18 (5.125)	77.77 (3.062)	73.6	17.0	12.7	----	88.9	MKM 1572	M16 x 50	245
		1110-64-48M16									M16 x 2		-----	---	
102 ^④	4	1109-64-64M16	139.5	162.0	38.0	130.18 (5.125)	77.77 (3.062)	97.3	17.0	12.7	----	114.3	MKM 1572	M16 x 50	245
		1110-64-64M16									M16 x 2		-----	---	

① Order Separately ② 16 MPa Max ③ 10 MPa Max ④ 2.5 MPa Max
* Non Standard Bolt For This Flange Size.

MATERIAL : STEEL
1/07

NOTE: DIMENSIONS ARE IN MILLIMETERS. INCH EQUIVALENTS IN ().