

Developers and Manufacturers of
Hydraulic Flanges & Components

SCHEDULE 80 BUTT WELD IN-LINE PIPE FLANGES

SAE BOLT PATTERN

62 SERIES

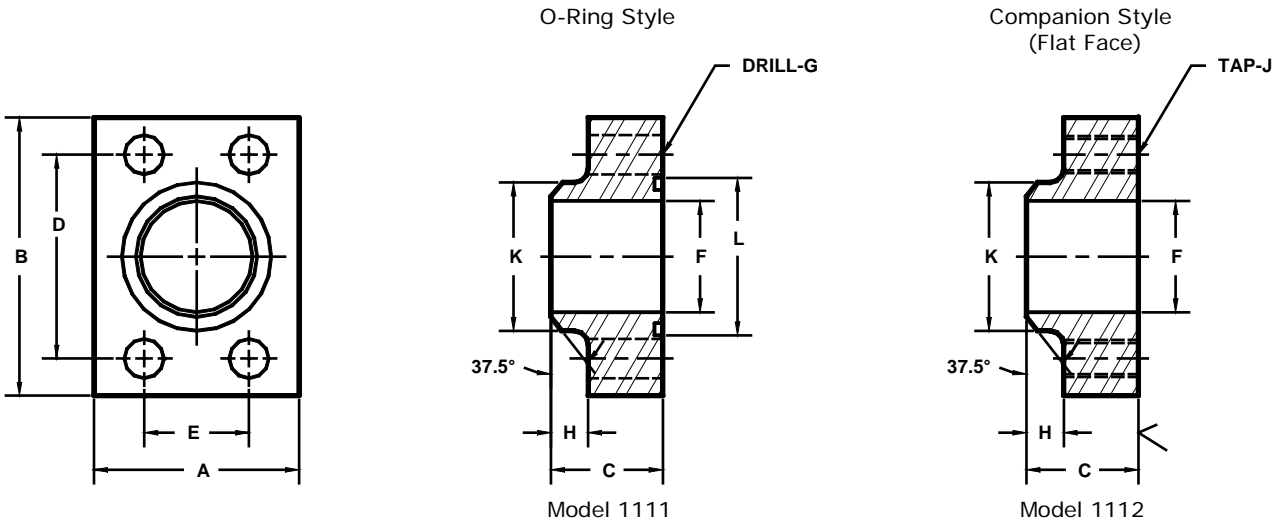

FLANGE SIZE	PIPE SIZE	PART NUMBER	A	B	C	D	E	F	G	H	J	K	L	MOUNTING KIT ^①		
														PART NO.	BOLT SIZE	O-RING
1/2	1/2	1111-08-08	1.75	2.22	1.25	1.594	.718	.53	.34	.38	-----	.88	1.000	MK 512	5/16-18 X 1 1/2	210
		1112-08-08							---				5/16-18	---	---	
3/4	1/2	1111-12-08	2.00	2.81	1.25	2.000	.937	.53	.41	.38	-----	.88	1.250	MK 1525	3/8-16 X 1 1/2	214
		1112-12-08							---				3/8-16	---	---	
3/4	3/4	1111-12-12	2.00	2.81	1.25	2.000	.937	.75	.41	.38	-----	1.12	1.250	MK 1525	3/8-16 X 1 1/2	214
		1112-12-12							---				3/8-16	---	---	
1	3/4	1111-16-12	2.25	3.19	1.25	2.250	1.093	.75	.47	.38	-----	1.12	1.562	MK 513	7/16-14 X 1 3/4	219
		1112-16-12							---				7/16-14	---	---	
1	1	1111-16-16	2.25	3.19	1.25	2.250	1.093	.94	.47	.38	-----	1.38	1.562	MK 513	7/16-14 X 1 3/4	219
		1112-16-16							---				7/16-14	---	---	
1 1/4	1	1111-20-16	2.75	3.75	1.25	2.625	1.250	.94	.53	.38	-----	1.38	1.750	MK 529	1/2-13 X 1 3/4	222
		1112-20-16							---				1/2-13	---	---	
1 1/4	1 1/4	1111-20-20	2.75	3.75	1.25	2.625	1.250	1.25	.53	.38	-----	1.75	1.750	MK 529	1/2-13 X 1 3/4	222
		1112-20-20							---				1/2-13	---	---	
1 1/2	1 1/4	1111-24-20	3.25	4.50	1.50	3.125	1.437	1.25	.66	.50	-----	1.75	2.125	MK 562	5/8-11 X 2	225
		1112-24-20							---				5/8-11	---	---	
1 1/2	1 1/2	1111-24-24	3.25	4.50	1.50	3.125	1.437	1.50	.66	.50	-----	2.00	2.125	MK 562	5/8-11 X 2	225
		1112-24-24							---				5/8-11	---	---	
2	1 1/2	1111-32-24	4.00	5.25	1.75	3.812	1.750	1.50	.78	.50	-----	2.00	2.500	MK 1548	3/4-10 X 2 1/2	228
		1112-32-24							---				3/4-10	---	---	
2	2	1111-32-32	4.00	5.25	1.75	3.812	1.750	1.94	.78	.50	-----	2.50	2.500	MK 1548	3/4-10 X 2 1/2	228
		1112-32-32							---				3/4-10	---	---	
2 1/2 ^②	2	1111-40-32	5.00	6.88	2.00	4.875	2.312	1.94	.94	.50	-----	2.50	3.000	MK 1575	7/8-9 X 2 3/4	232
		1112-40-32							---				7/8-9	---	---	
2 1/2 ^②	2 1/2	1111-40-40	5.00	6.88	2.00	4.875	2.312	2.32	.94	.50	-----	3.00	3.000	MK 1575	7/8-9 X 2 3/4	232
		1112-40-40							---				7/8-9	---	---	
3 ^②	3	1111-48-48	6.00	8.50	2.50	6.000	2.812	2.90	1.19	.50	-----	3.50	3.625	MK 1776	1 1/8-7 X 4	237
		1112-48-48							---				1 1/8-7	---	---	

① Order Separately ② Not included in SAE J518 specifications

MATERIAL : STEEL
1/07