

Developers and Manufacturers of Hydraulic Flanges & Components

SCHEDULE 80 BUTT WELD ELBOW PIPE FLANGES

SAE BOLT PATTERN

62 SERIES

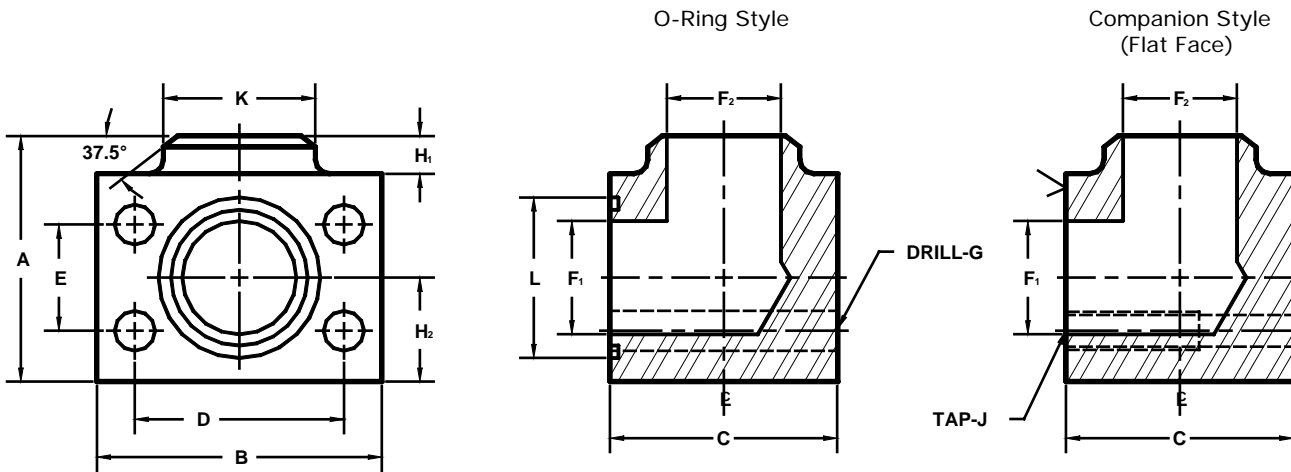

Model 1139

Model 1140

FLANGE SIZE	PIPE SIZE	PART NUMBER	A	B	C	D	E	F ₁	F ₂	G	H ₁	H ₂	J	K	L	MOUNTING KIT [Ⓢ]		
																PART NO.	BOLT SIZE	O-RING
1/2	1/2	1139-08-08	2.25	2.22	1.46	1.594	.718	.50	.53	.34	.38	.88	-----	.88	1.000	MK 541	5/16-18 X 2	210
		1140-08-08																
3/4	1/2	1139-12-08	2.50	2.81	1.70	2.000	.937	.75	.53	.41	.38	1.00	-----	.88	1.250	MK 542	3/8-16 X 2 1/2	214
		1140-12-08																
3/4	3/4	1139-12-12	2.50	2.81	1.70	2.000	.937	.75	.73	.41	.38	1.00	-----	1.12	1.250	MK 542	3/8-16 X 2 1/2	214
		1140-12-12																
1	3/4	1139-16-12	2.75	3.19	2.21	2.250	1.093	1.00	.73	.47	.38	1.12	-----	1.12	1.562	MK 2533	7/16-14 X 3	219
		1140-16-12																
1	1	1139-16-16	2.75	3.19	2.21	2.250	1.093	1.00	.94	.47	.38	1.12	-----	1.38	1.562	MK 2533	7/16-14 X 3	219
		1140-16-16																
1 1/4	1	1139-20-16	3.25	3.75	2.44	2.625	1.250	1.25	.94	.53	.38	1.38	-----	1.38	1.750	MK 552	1/2-13 X 3 1/4	222
		1140-20-16																
1 1/4	1 1/4	1139-20-20	3.25	3.75	2.44	2.625	1.250	1.25	1.23	.53	.38	1.38	-----	1.75	1.750	MK 552	1/2-13 X 3 1/4	222
		1140-20-20																
1 1/2	1 1/4	1139-24-20	3.75	4.50	2.96	3.125	1.437	1.50	1.23	.66	.50	1.62	-----	1.75	2.125	MK 553	5/8-11 X 4	225
		1140-24-20																
1 1/2	1 1/2	1139-24-24	3.75	4.50	2.96	3.125	1.437	1.50	1.48	.66	.50	1.62	-----	2.00	2.125	MK 553	5/8-11 X 4	225
		1140-24-24																
2	1 1/2	1139-32-24	4.50	5.25	3.46	3.812	1.750	1.94	1.48	.78	.50	2.00	-----	2.00	2.500	MK 554	3/4-10 X 4 1/2	228
		1140-32-24																
2	2	1139-32-32	4.50	5.25	3.46	3.812	1.750	1.94	1.94	.78	.50	2.00	-----	2.50	2.500	MK 554	3/4-10 X 4 1/2	228
		1140-32-32																
2 1/2 [Ⓢ]	2	1139-40-32	5.50	6.88	4.50	4.875	2.312	2.44	1.94	.94	.50	2.50	-----	2.50	3.000	MK 2557	7/8-9 X 6	232
		1140-40-32																
2 1/2 [Ⓢ]	2 1/2	1139-40-40	5.50	6.88	4.50	4.875	2.312	2.44	2.32	.94	.50	2.50	-----	3.00	3.000	MK 2557	7/8-9 X 6	232
		1140-40-40																
3 [Ⓢ]	3	1139-48-48	6.50	8.50	5.00	6.000	2.812	2.94	2.90	1.19	.50	3.00	-----	3.50	3.625	MK 756	1 1/8-7 X 7	237
		1140-48-48																

Ⓢ Order Separately Ⓢ Not included in SAE J518 specifications

MATERIAL : STEEL
1/07