

Developers and Manufacturers of Hydraulic Flanges & Components

SAE STRAIGHT THREADED IN-LINE FLANGES

SAE BOLT PATTERN

61 SERIES

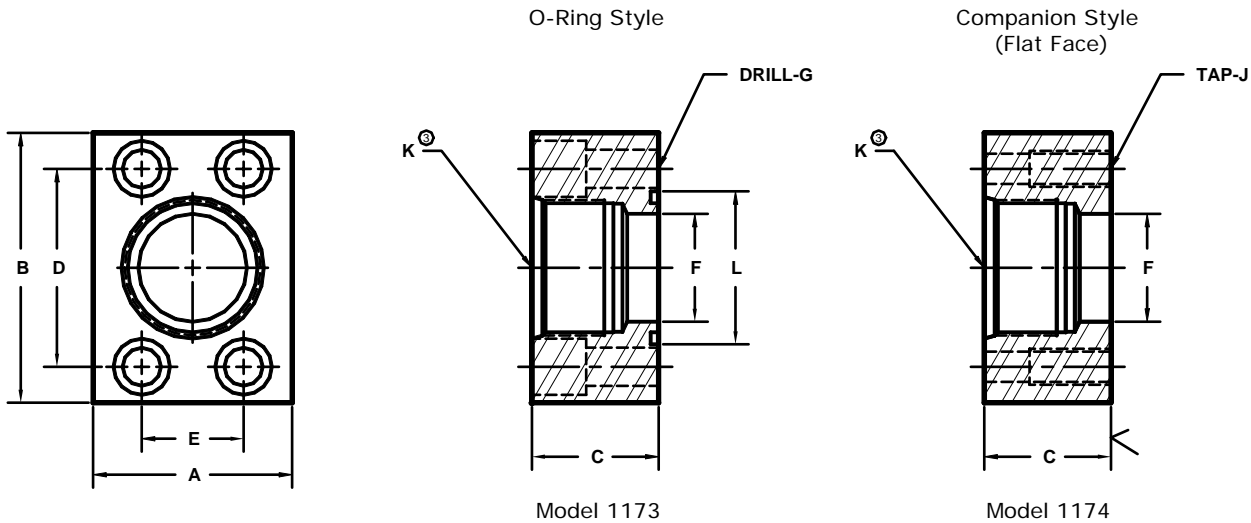

FLANGE SIZE	PORT SIZE	PART NUMBER	A	B	C	D	E	F	G	J	K	L	MOUNTING KIT [Ⓢ]		
													PART NO.	BOLT SIZE	O-RING
1/2	-4	1173-08-04	1.50	2.12	1.25	1.500	.688	.37	.34	-----	7/16-20	1.000	MK 501	5/16-18 X 1 1/4	210
		1174-08-04							---						
1/2	-6	1173-08-06	1.50	2.12	1.25	1.500	.688	.47	.34	-----	9/16-18	1.000	MK 501	5/16-18 X 1 1/4	210
		1174-08-06							---						
1/2	-8	1173-08-08	1.50	2.12	1.25	1.500	.688	.50	.34	-----	3/4-16	1.000	MK 501	5/16-18 X 1 1/4	210
		1174-08-08							---						
3/4	-6	1173-12-06	1.75	2.62	1.50	1.875	.875	.47	.41	-----	9/16-18	1.250	MK 1525	3/8-16 X 1 1/2	214
		1174-12-06							---						
3/4	-8	1173-12-08	1.75	2.62	1.50	1.875	.875	.66	.41	-----	3/4-16	1.250	MK 1525	3/8-16 X 1 1/2	214
		1174-12-08							---						
3/4	-10	1173-12-10	1.75	2.62	1.50	1.875	.875	.50	.41	-----	7/8-14	1.250	MK 1525	3/8-16 X 1 1/2	214
		1174-12-10							---						
3/4	-12	1173-12-12	1.75	2.62	1.50	1.875	.875	.75	.41	-----	1 1/16-12	1.250	MK 1525	3/8-16 X 1 1/2	214
		1174-12-12							---						
3/4	-16	-----	2.00	2.62	2.50	1.875	.875	.75	---	-----	1 5/16-12	---	-----	-----	---
		1174-12-16							---						
1	-8	1173-16-08	2.00	2.82	1.50	2.062	1.031	.66	.41	-----	3/4-16	1.562	MK 1542	3/8-16 X 1 1/2	219
		1174-16-08							---						
1	-10	1173-16-10	2.00	2.82	1.50	2.062	1.031	.78	.41	-----	7/8-14	1.562	MK 1542	3/8-16 X 1 1/2	219
		1174-16-10							---						
1	-12	1173-16-12	2.00	2.82	1.50	2.062	1.031	.94	.41	-----	1 1/16-12	1.562	MK 1542	3/8-16 X 1 1/2	219
		1174-16-12							---						
1	-14	1173-16-14	2.00	2.82	1.50	2.062	1.031	.75	.41	-----	1 3/16-12	1.562	MK 1542	3/8-16 X 1 1/2	219
		1174-16-14							---						
1	-16	1173-16-16	2.00	2.82	1.50	2.062	1.031	1.00	.41	-----	1 5/16-12	1.562	MK 1542	3/8-16 X 1 1/2	219
		1174-16-16							---						
1	-20	-----	2.50	3.00	3.00	2.062	1.031	1.00	---	-----	1 5/8-12	---	-----	-----	---
		1174-16-20							---						

① Order Separately

③ The pressure rating of the assembly should not exceed the lower of the flange pad or the fitting. Check the fitting manufacturer for details.

MATERIAL : STEEL
1/07

Developers and Manufacturers of Hydraulic Flanges & Components

SAE STRAIGHT THREADED IN-LINE FLANGES

SAE BOLT PATTERN

61 SERIES

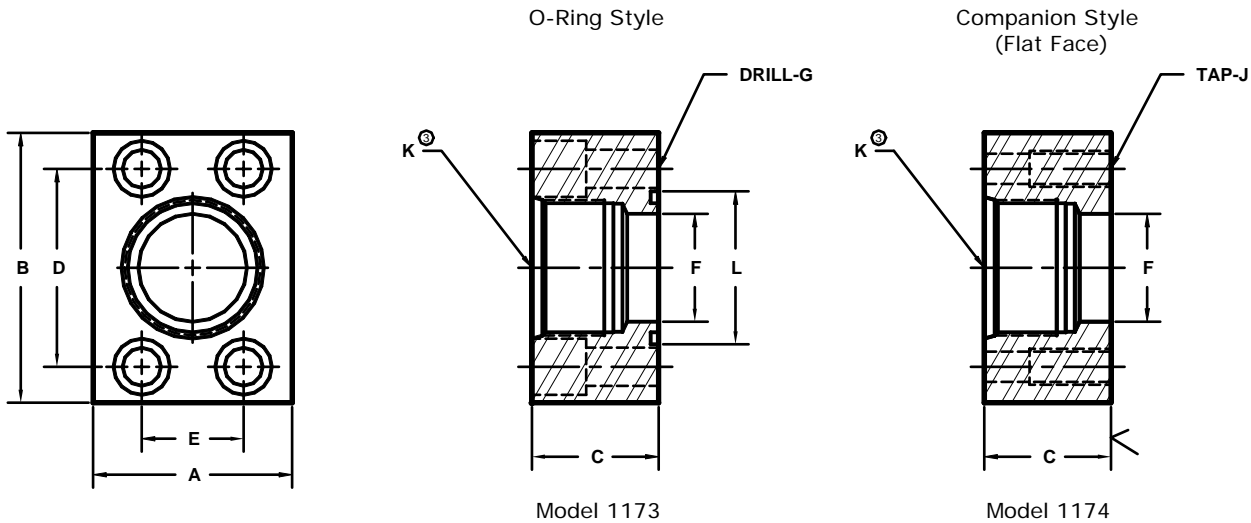

FLANGE SIZE	PORT SIZE	PART NUMBER	A	B	C	D	E	F	G	J	K	L	MOUNTING KIT [Ⓢ]		
													PART NO.	BOLT SIZE	O-RING
1 1/4	-12	1173-20-12	2.50	3.19	1.50	2.312	1.188	.94	.47	-----	1 1/16-12	1.750	MK 1527	7/16-14 X 1 1/2	222
		1174-20-12											-----	-----	---
1 1/4	-16	1173-20-16	2.50	3.19	1.50	2.312	1.188	1.20	.47	-----	1 5/16-12	1.750	MK 1527	7/16-14 X 1 1/2	222
		1174-20-16											-----	-----	---
1 1/4	-20	1173-20-20	2.50	3.19	1.50	2.312	1.188	1.25	.47	-----	1 5/8-12	1.750	MK 1527	7/16-14 X 1 1/2	222
		1174-20-20											-----	-----	---
1 1/4	-24	-----	3.00	3.19	3.00	2.312	1.188	1.25	---	-----	1 7/8-12	---	-----	-----	---
		1174-20-24											-----	-----	---
1 1/2	-16	1173-24-16	2.75	3.75	1.75	2.750	1.406	1.20	.53	-----	1 5/16-12	2.125	MK 1547	1/2-13 X 1 3/4	225
		1174-24-16											-----	-----	---
1 1/2	-20	1173-24-20	2.75	3.75	1.75	2.750	1.406	1.50	.53	-----	1 5/8-12	2.125	MK 1547	1/2-13 X 1 3/4	225
		1174-24-20											-----	-----	---
1 1/2	-24	1173-24-24	2.75	3.75	1.75	2.750	1.406	1.50	.53	-----	1 7/8-12	2.125	MK 1547	1/2-13 X 1 3/4	225
		1174-24-24											-----	-----	---
1 1/2	-32	-----	3.50	3.75	3.50	2.750	1.406	1.50	---	-----	2 1/2-12	---	-----	-----	---
		1174-24-32											-----	-----	---
2	-20	1173-32-20	3.25	4.00	1.75	3.062	1.688	1.50	.53	-----	1 5/8-12	2.500	MK 582	1/2-13 X 1 3/4	228
		1174-32-20											-----	-----	---
2	-24	1173-32-24	3.25	4.00	1.75	3.062	1.688	1.77	.53	-----	1 7/8-12	2.500	MK 582	1/2-13 X 1 3/4	228
		1174-32-24											-----	-----	---
2	-32	-----	3.25	4.00	1.75	3.062	1.688	1.94	---	-----	2 1/2-12	---	-----	-----	---
		1174-32-32											-----	-----	---
2 1/2 [Ⓢ]	-20	1173-40-20	4.00	4.50	1.75	3.500	2.000	1.50	.53	-----	1 5/8-12	3.000	MK 1528	1/2-13 X 1 3/4	232
		1174-40-20											-----	-----	---
2 1/2 [Ⓢ]	-24	1173-40-24	4.00	4.50	1.75	3.500	2.000	1.77	.53	-----	1 7/8-12	3.000	MK 1528	1/2-13 X 1 3/4	232
		1174-40-24											-----	-----	---
2 1/2 [Ⓢ]	-32	1173-40-32	4.00	4.50	1.75	3.500	2.000	2.39	.53	-----	2 1/2-12	3.000	MK 1528	1/2-13 X 1 3/4	232
		1174-40-32											-----	-----	---

Ⓢ Order Separately Ⓢ 2500 PSI Max Ⓢ The pressure rating of the assembly should not exceed the lower of the flange pad or the fitting. Check the fitting manufacturer for details. MATERIAL : STEEL
1/07