

Developers and Manufacturers of Hydraulic Flanges & Components

SAE STRAIGHT THREADED ELBOW FLANGES

SAE BOLT PATTERN

61 SERIES

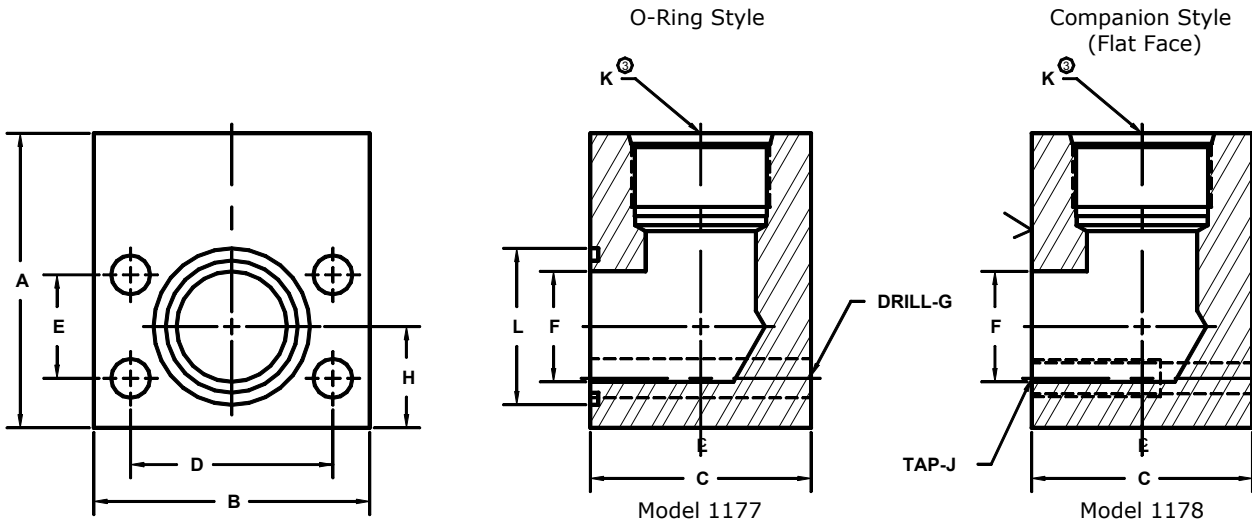

FLANGE SIZE	PORT SIZE	PART NUMBER	A	B	C	D	E	F	G	H	J	K	L	MOUNTING KIT ^①		
														PART NO.	BOLT SIZE	O-RING
1/2	-4	1177-08-04	2.00	2.12	1.44	1.500	.688	.50	.34	.75	-----	7/16-20	1.000	MK 541	5/16-18 X 2	210
		1178-08-04							---					5/16-18	-----	---
1/2	-6	1177-08-06	2.00	2.12	1.44	1.500	.688	.50	.34	.75	-----	9/16-18	1.000	MK 541	5/16-18 X 2	210
		1178-08-06							---					5/16-18	-----	---
1/2	-8	1177-08-08	2.00	2.12	1.44	1.500	.688	.50	.34	.75	-----	3/4-16	1.000	MK 541	5/16-18 X 2	210
		1178-08-08							---					5/16-18	-----	---
3/4	-6	1177-12-06	2.50	2.62	1.70	1.875	.875	.75	.41	.88	-----	9/16-18	1.250	MK 542	3/8-16 X 2 1/2	214
		1178-12-06							---					3/8-16	-----	---
3/4	-8	1177-12-08	2.50	2.62	1.70	1.875	.875	.75	.41	.88	-----	3/4-16	1.250	MK 542	3/8-16 X 2 1/2	214
		1178-12-08							---					3/8-16	-----	---
3/4	-10	1177-12-10	2.50	2.62	1.70	1.875	.875	.75	.41	.88	-----	7/8-14	1.250	MK 542	3/8-16 X 2 1/2	214
		1178-12-10							---					3/8-16	-----	---
3/4	-12	1177-12-12	2.50	2.62	1.70	1.875	.875	.75	.41	.88	-----	1 1/16-12	1.250	MK 542	3/8-16 X 2 1/2	214
		1178-12-12							---					3/8-16	-----	---
3/4	-16	1177-12-16	3.00	2.62	2.00	1.875	.875	.75	.41	.88	-----	1 5/16-12	1.250	MK 3513	3/8-16 X 2 3/4	214
		1178-12-16							---					3/8-16	-----	---
1	-8	1177-16-08	3.00	2.82	1.94	2.062	1.031	1.00	.41	1.00	-----	3/4-16	1.562	MK 543	3/8-16 X 2 3/4	219
		1178-16-08							---					3/8-16	-----	---
1	-10	1177-16-10	3.00	2.82	1.94	2.062	1.031	1.00	.41	1.00	-----	7/8-14	1.562	MK 543	3/8-16 X 2 3/4	219
		1178-16-10							---					3/8-16	-----	---
1	-12	1177-16-12	3.00	2.82	1.94	2.062	1.031	1.00	.41	1.00	-----	1 1/16-12	1.562	MK 543	3/8-16 X 2 3/4	219
		1178-16-12							---					3/8-16	-----	---
1	-14	1177-16-14	3.00	2.82	1.94	2.062	1.031	1.00	.41	1.00	-----	1 3/16-12	1.562	MK 543	3/8-16 X 2 3/4	219
		1178-16-14							---					3/8-16	-----	---
1	-16	1177-16-16	3.00	2.82	1.94	2.062	1.031	1.00	.41	1.00	-----	1 5/16-12	1.562	MK 543	3/8-16 X 2 3/4	219
		1178-16-16							---					3/8-16	-----	---
1	-20	1177-16-20	3.50	2.82	2.50	2.062	1.031	1.00	.41	1.00	-----	1 5/8-12	1.562	MK 577	3/8-16 X 3 1/4	219
		1178-16-20							---					3/8-16	-----	---

① Order Separately

② The pressure rating of the assembly should not exceed the lower of the flange pad or the fitting. Check the fitting manufacturer for details.

MATERIAL : STEEL
1/07

Developers and Manufacturers of Hydraulic Flanges & Components

SAE STRAIGHT THREADED ELBOW FLANGES

SAE BOLT PATTERN

61 SERIES

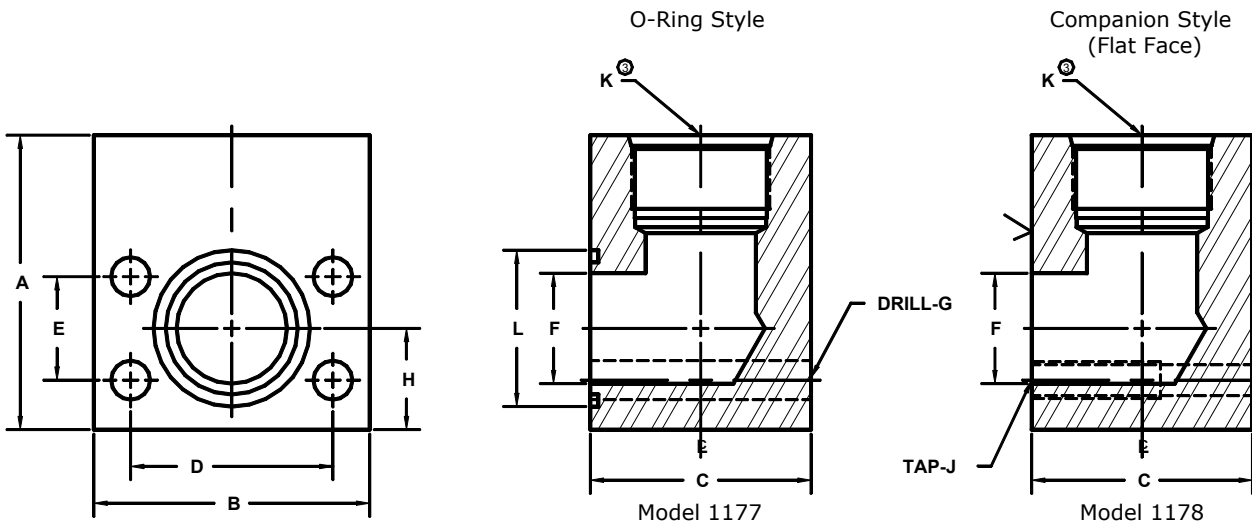

FLANGE SIZE	PORT SIZE	PART NUMBER	A	B	C	D	E	F	G	H	J	K	L	MOUNTING KIT ^①		
														PART NO.	BOLT SIZE	O-RING
1 1/4	-12	1177-20-12	3.50	3.19	2.40	2.312	1.188	1.25	.47	1.25	-----	1 1/16-12	1.750	MK 578	7/16-14 X 3 1/4	222
		1178-20-12														
1 1/4	-16	1177-20-16	3.50	3.19	2.40	2.312	1.188	1.25	.47	1.25	-----	1 5/16-12	1.750	MK 578	7/16-14 X 3 1/4	222
		1178-20-16														
1 1/4	-20	1177-20-20	3.50	3.19	2.40	2.312	1.188	1.25	.47	1.25	-----	1 5/8-12	1.750	MK 578	7/16-14 X 3 1/4	222
		1178-20-20														
1 1/4	-24	1177-20-24	4.00	3.19	3.00	2.312	1.188	1.25	.47	1.25	-----	1 7/8-12	1.750	MK 591	7/16-14 X 4	222
		1178-20-24														
1 1/2	-16	1177-24-16	4.00	3.75	2.90	2.750	1.406	1.50	.53	1.38	-----	1 5/16-12	2.125	MK 545	1/2-13 X 4	225
		1178-24-16														
1 1/2	-20	1177-24-20	4.00	3.75	2.90	2.750	1.406	1.50	.53	1.38	-----	1 5/8-12	2.125	MK 545	1/2-13 X 4	225
		1178-24-20														
1 1/2	-24	1177-24-24	4.00	3.75	2.90	2.750	1.406	1.50	.53	1.38	-----	1 7/8-12	2.125	MK 545	1/2-13 X 4	225
		1178-24-24														
1 1/2	-32	1177-24-32	4.00	4.00	4.00	2.750	1.406	1.50	.53	1.38	-----	2 1/2-12	2.125	MK 1508	1/2-13 X 5	225
		1178-24-32														
2	-20	1177-32-20	4.50	4.00	3.00	3.062	1.688	1.94	.53	1.62	-----	1 5/8-12	2.500	MK 558	1/2-13 X 4	228
		1178-32-20														
2	-24	1177-32-24	4.50	4.00	3.00	3.062	1.688	1.94	.53	1.62	-----	1 7/8-12	2.500	MK 558	1/2-13 X 4	228
		1178-32-24														
2	-32	1177-32-32	4.25	4.00	3.94	3.062	1.688	1.94	.53	1.62	-----	2 1/2-12	2.500	MK 592	1/2-13 X 5	228
		1178-32-32														
2 1/2 ^②	-20	1177-40-20	5.00	4.50	3.94	3.500	2.000	2.44	.53	2.00	-----	1 5/8-12	3.000	MK 547	1/2-13 X 5	232
		1178-40-20														
2 1/2 ^②	-24	1177-40-24	5.00	4.50	3.94	3.500	2.000	2.44	.53	2.00	-----	1 7/8-12	3.000	MK 547	1/2-13 X 5	232
		1178-40-24														
2 1/2 ^②	-32	1177-40-32	5.00	4.50	3.94	3.500	2.000	2.44	.53	2.00	-----	2 1/2-12	3.000	MK 547	1/2-13 X 5	232
		1178-40-32														

① Order Separately ② 2500 PSI Max ③ The pressure rating of the assembly should not exceed the lower of the flange pad or the fitting. Check the fitting manufacturer for details.

MATERIAL : STEEL
1/07