

Developers and Manufacturers of
Hydraulic Flanges & Components

FLANGED RUN TEE FLANGES

SAE BOLT PATTERN

62 SERIES

O-Ring Style

Companion Style
(Flat Face)

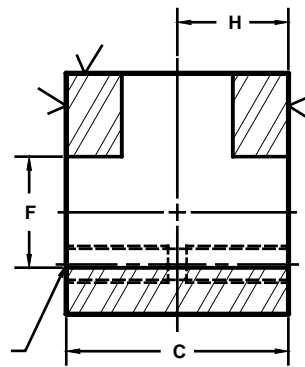
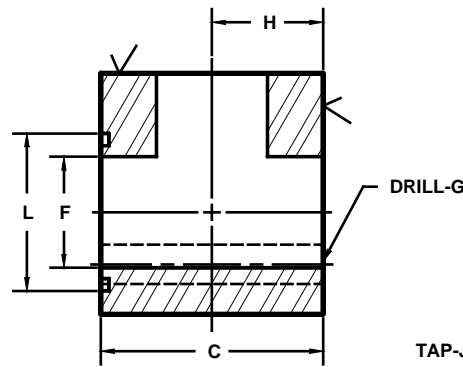
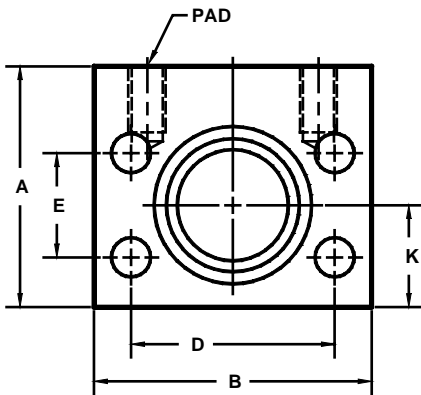

Model 1207

Model 1208

FLANGE SIZE	PAD SIZE	PART NUMBER	A	B	C	D	E	F	G	H	J	K	L	O-RING ^①
1/2	1/2	1207-08-08	2.00	2.22	2.00	1.594	.718	.50	.34	.94	-----	.81	1.000	210
		-----							---				---	
1/2	3/4	1207-08-12	2.50	2.82	2.50	1.594	.718	.50	.34	1.19	-----	.88	1.000	210
		-----							---				---	
3/4	1/2	1207-12-08	2.50	2.82	2.50	2.000	.937	.75	.41	1.19	-----	1.06	1.250	214
		1208-12-08							---				3/8-16	---
3/4	3/4	1207-12-12	2.50	2.82	2.50	2.000	.937	.75	.41	1.19	-----	1.06	1.250	214
		-----							---				---	
3/4	1	1207-12-16	3.00	3.19	3.00	2.000	.937	.75	.41	1.38	-----	1.00	1.250	214
		-----							---				---	
3/4	1 1/4	1207-12-20	3.00	3.75	3.50	2.000	.937	.75	.41	1.62	-----	1.00	1.250	214
		-----							---				---	
1	1/2	1207-16-08	3.00	3.19	3.00	2.250	1.093	1.00	.47	1.38	-----	1.38	1.562	219
		1208-16-08							---				7/16-14	---
1	3/4	1207-16-12	3.00	3.19	3.00	2.250	1.093	1.00	.47	1.38	-----	1.38	1.562	219
		1208-16-12							---				7/16-14	---
1	1	1207-16-16	3.00	3.19	3.00	2.250	1.093	1.00	.47	1.38	-----	1.38	1.562	219
		-----							---				---	
1	1 1/4	1207-16-20	3.50	3.75	3.50	2.250	1.093	1.00	.47	1.62	-----	1.41	1.562	219
		-----							---				---	
1	1 1/2	1207-16-24	3.50	4.50	4.00	2.250	1.093	1.00	.47	1.90	-----	1.31	1.562	219
		-----							---				---	
1 1/4	3/4	1207-20-12	3.50	3.75	3.00	2.625	1.250	1.25	.53	1.41	-----	1.50	1.750	222
		1208-20-12							---				1/2-13	---
1 1/4	1	1207-20-16	3.50	3.75	3.00	2.625	1.250	1.25	.53	1.41	-----	1.50	1.750	222
		1208-20-16							---				1/2-13	---
1 1/4	1 1/4	1207-20-20	3.50	3.75	3.50	2.625	1.250	1.25	.53	1.62	-----	1.41	1.750	222
		-----							---				---	

① Included

MATERIAL : STEEL

1/07

Developers and Manufacturers of
Hydraulic Flanges & Components

FLANGED RUN TEE FLANGES

SAE BOLT PATTERN

62 SERIES

O-Ring Style

Companion Style
(Flat Face)

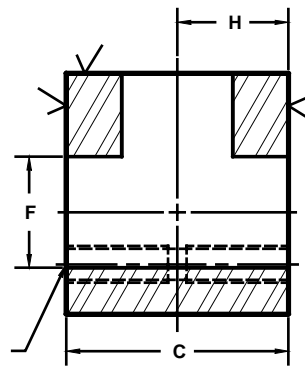
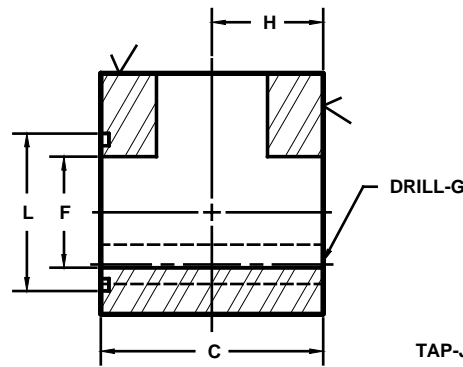
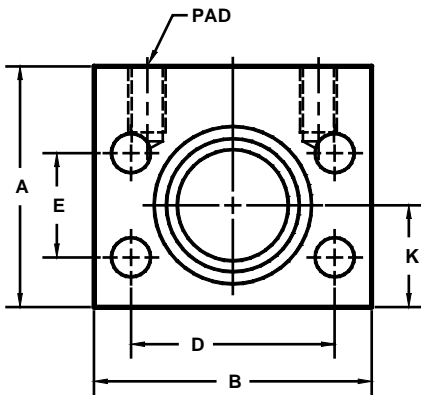

Model 1207

Model 1208

FLANGE SIZE	PAD SIZE	PART NUMBER	A	B	C	D	E	F	G	H	J	K	L	O-RING ^①
1 1/4	1 1/2	1207-20-24	4.00	4.50	4.00	2.625	1.250	1.25	.53	1.90	-----	1.75	1.750	222
		-----							---				---	
1 1/4	2	1207-20-32	4.00	5.25	5.00	2.625	1.250	1.25	.53	2.50	-----	1.50	1.750	222
		-----							---				---	
1 1/2	1	1207-24-16	3.50	4.50	3.00	3.125	1.437	1.50	.66	1.38	-----	1.62	2.125	225
		1208-24-16							---				5/8-11	---
1 1/2	1 1/4	1207-24-20	4.00	4.50	4.00	3.125	1.437	1.50	.66	1.88	-----	1.75	2.125	225
		1208-24-20							---				5/8-11	---
1 1/2	1 1/2	1207-24-24	4.00	4.50	4.00	3.125	1.437	1.50	.66	1.88	-----	1.75	2.125	225
		-----							---				---	---
1 1/2	2	1207-24-32	4.50	5.25	5.00	3.125	1.437	1.50	.66	2.50	-----	1.75	2.125	225
		-----							---				---	---
2	1	1207-32-16	5.00	5.25	3.50	3.812	1.750	1.94	.78	1.75	-----	2.00	2.500	228
		1208-32-16							---				3/4-10	---
2	1 1/4	1207-32-20	5.00	5.25	4.00	3.812	1.750	1.94	.78	2.00	-----	2.25	2.500	228
		1208-32-20							---				3/4-10	---
2	1 1/2	1207-32-24	5.00	5.25	5.00	3.812	1.750	1.94	.78	2.25	-----	2.50	2.500	228
		1208-32-24							---				3/4-10	---
2	2	1207-32-32	5.00	5.25	5.00	3.812	1.750	1.94	.78	2.25	-----	2.50	2.500	228
		-----							---				---	---
2 1/2 ^②	2	1207-40-32	6.00	7.00	5.00	4.875	2.312	2.44	.94	2.50	-----	2.50	3.000	232
		1208-40-32							---				7/8-9	---
2 1/2 ^②	2 1/2	1207-40-40	6.00	7.00	5.00	4.875	2.312	2.44	.94	2.50	-----	2.50	3.000	232
		-----							---				---	---
3 ^②	2	1207-48-32	6.50	8.50	5.00	6.000	2.812	2.94	1.19	2.25	-----	3.00	3.625	237
		1208-48-32							---				1 1/8-7	---
3 ^②	3	1207-48-48	7.00	8.50	6.00	6.000	2.812	2.94	1.19	2.96	-----	3.00	3.625	237
		-----							---				---	---

① Included ② Not included in SAE J518 specifications

MATERIAL : STEEL

1/07