

Developers and Manufacturers of Hydraulic Flanges & Components

## JIS B 2291, 210K, SAE ST THREADED IN-LINE FLANGES

TYPE SSA & SSB

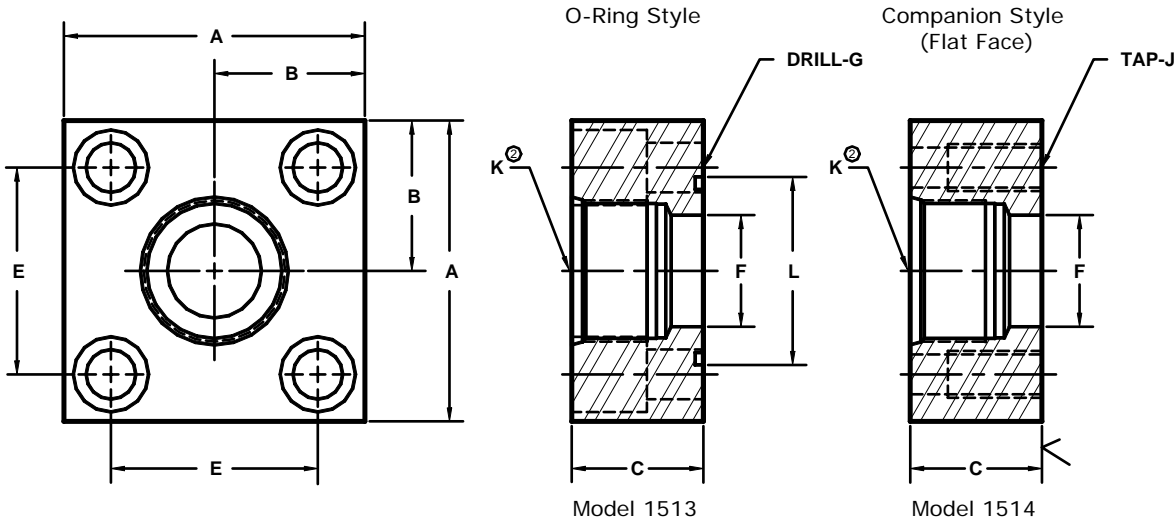

FLANGE SIZE	PORT SIZE	PART NUMBER	A	B	C	E <sub>mm</sub>	E	F	G <sub>mm</sub>	J <sub>mm</sub>	K	L	MOUNTING KIT <sup>Ⓞ</sup>		
													PART NO.	BOLT SIZE	O-RING
15	-8	1513-08-08M	2.25	1.12	1.25	36.0	1.417	.63	11.0	----	3/4-16	1.181	MKM 4586	M10 x 35	G25
		1514-08-08M							---	M10 x 1.5		---	---	---	
20	-8	1513-12-08M	2.50	1.25	1.50	40.0	1.574	.66	11.0	----	3/4-16	1.378	MKM 5505	M10 x 40	G30
		1514-12-08M							---	M10 x 1.5		---	---	---	
20	-10	1513-12-10M	2.50	1.25	1.50	40.0	1.574	.50	11.0	----	7/8-14	1.378	MKM 5505	M10 x 40	G30
		1514-12-10M							---	M10 x 1.5		---	---	---	
20	-12	1513-12-12M	2.50	1.25	1.50	40.0	1.574	.75	11.0	----	1 1/16-12	1.378	MKM 5505	M10 x 40	G30
		1514-12-12M							---	M10 x 1.5		---	---	---	
25	-12	1513-16-12M	3.00	1.50	1.50	48.0	1.890	.94	13.0	----	1 1/16-12	1.575	MKM 5506	M12 x 40	G35
		1514-16-12M							---	M12 x 1.75		---	---	---	
25	-14	1513-16-14M	3.00	1.50	1.50	48.0	1.890	.75	13.0	----	1 3/16-12	1.575	MKM 5506	M12 x 40	G35
		1514-16-14M							---	M12 x 1.75		---	---	---	
25	-16	1513-16-16M	3.00	1.50	1.50	48.0	1.890	1.00	13.0	----	1 5/16-12	1.575	MKM 5506	M12 x 40	G35
		1514-16-16M							---	M12 x 1.75		---	---	---	
32	-16	1513-20-16M	3.25	1.62	1.50	56.0	2.205	1.20	13.0	----	1 5/16-12	1.772	MKM 5526	M12 x 40	G40
		1514-20-16M							---	M12 x 1.75		---	---	---	
32	-20	1513-20-20M	3.25	1.62	1.50	56.0	2.205	1.25	13.0	----	1 5/8-12	1.772	MKM 5526	M12 x 40	G40
		1514-20-20M							---	M12 x 1.75		---	---	---	
40	-16	1513-24-16M	3.75	1.88	1.75	65.0	2.559	1.20	18.0	----	1 5/16-12	2.165	MKM 4590	M16 x 45	G50
		1514-24-16M							---	M16 x 2		---	---	---	
40	-20	1513-24-20M	3.75	1.88	1.75	65.0	2.559	1.50	18.0	----	1 5/8-12	2.165	MKM 4590	M16 x 45	G50
		1514-24-20M							---	M16 x 2		---	---	---	
40	-24	1513-24-24M	3.75	1.88	1.75	65.0	2.559	1.50	18.0	----	1 7/8-12	2.165	MKM 4590	M16 x 45	G50
		1514-24-24M							---	M16 x 2		---	---	---	
50	-24	1513-32-24M	4.00	2.00	1.75	73.0	2.874	1.77	18.0	----	1 7/8-12	2.559	MKM 4591	M16 x 45	G60
		1514-32-24M							---	M16 x 2		---	---	---	
50	-32	1513-32-32M	4.00	2.00	1.75	73.0	2.874	1.94	18.0	----	2 1/2-12	2.559	MKM 4591	M16 x 45	G60
		1514-32-32M							---	M16 x 2		---	---	---	

① Order Separately    ② SAE has a lower rating on the St. Thd. fitting than the flange pad. Check the fitting manufacturer for details.    MATERIAL : STEEL 1/07

NOTE: DIMENSIONS ARE IN INCHES UNLESS OTHERWISE NOTED.