

Developers and Manufacturers of Hydraulic Flanges & Components

ISO 6149 THREADED IN-LINE FLANGES

SAE BOLT PATTERN

61 SERIES

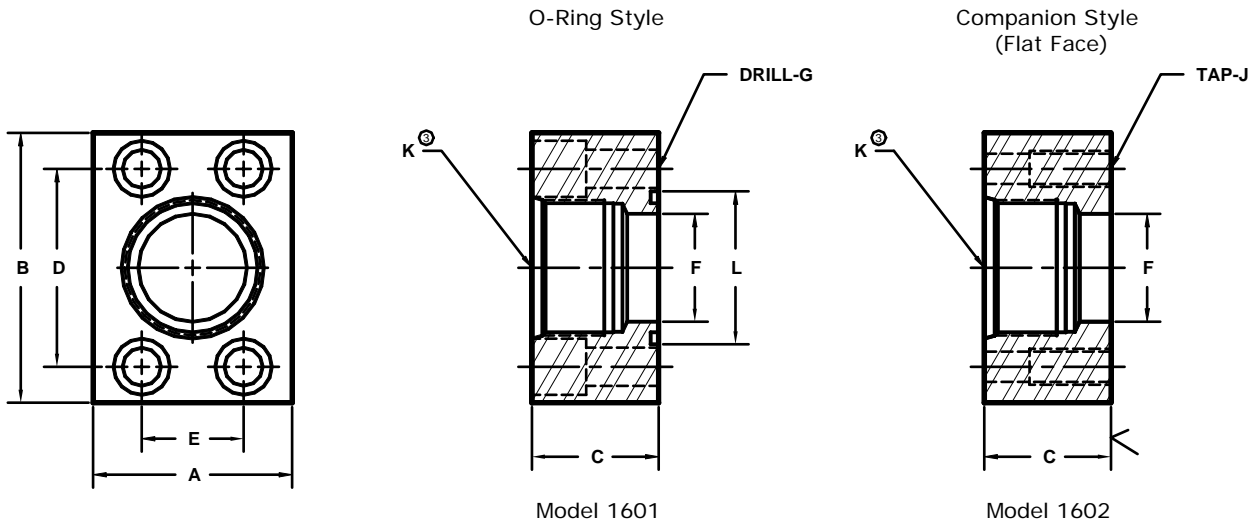

FLANGE SIZE	PORT SIZE	PART NUMBER	A	B	C	D	E	F	G	J	K	L	MOUNTING KIT [ⓐ]		
													PART NO.	BOLT SIZE	O-RING
1/2	-4	1601-08-04	1.50	2.12	1.25	1.500	.688	.37	.34	-----	M12 x 1.5	1.000	MK 501	5/16-18 X 1 1/4	210
		1602-08-04											-----	-----	---
1/2	-6	1601-08-06	1.50	2.12	1.25	1.500	.688	.47	.34	-----	M16 x 1.5	1.000	MK 501	5/16-18 X 1 1/4	210
		1602-08-06											-----	-----	---
1/2	-8	1601-08-08	1.50	2.12	1.25	1.500	.688	.50	.34	-----	M18 x 1.5	1.000	MK 501	5/16-18 X 1 1/4	210
		1602-08-08											-----	-----	---
3/4	-6	1601-12-06	1.75	2.62	1.50	1.875	.875	.47	.41	-----	M16 x 1.5	1.250	MK 1525	3/8-16 X 1 1/2	214
		1602-12-06											-----	-----	---
3/4	-8	1601-12-08	1.75	2.62	1.50	1.875	.875	.66	.41	-----	M18 x 1.5	1.250	MK 1525	3/8-16 X 1 1/2	214
		1602-12-08											-----	-----	---
3/4	-10	1601-12-10	1.75	2.62	1.50	1.875	.875	.50	.41	-----	M22 x 1.5	1.250	MK 1525	3/8-16 X 1 1/2	214
		1602-12-10											-----	-----	---
3/4	-12	1601-12-12	1.75	2.62	1.50	1.875	.875	.75	.41	-----	M27 x 2	1.250	MK 1525	3/8-16 X 1 1/2	214
		1602-12-12											-----	-----	---
3/4	-16	-----	2.00	2.62	2.50	1.875	.875	.75	---	-----	M33 x 2	---	-----	-----	---
		1602-12-16											-----	-----	---
1	-6	1601-16-06	2.00	2.82	1.50	2.062	1.031	.47	.41	-----	M16 x 1.5	1.562	MK 1542	3/8-16 X 1 1/2	219
		1602-16-06											-----	-----	---
1	-8	1601-16-08	2.00	2.82	1.50	2.062	1.031	.66	.41	-----	M18 x 1.5	1.562	MK 1542	3/8-16 X 1 1/2	219
		1602-16-08											-----	-----	---
1	-10	1601-16-10	2.00	2.82	1.50	2.062	1.031	.78	.41	-----	M22 x 1.5	1.562	MK 1542	3/8-16 X 1 1/2	219
		1602-16-10											-----	-----	---
1	-12	1601-16-12	2.00	2.82	1.50	2.062	1.031	.94	.41	-----	M27 x 2	1.562	MK 1542	3/8-16 X 1 1/2	219
		1602-16-12											-----	-----	---
1	-16	1601-16-16	2.00	2.82	1.50	2.062	1.031	1.00	.41	-----	M33 x 2	1.562	MK 1542	3/8-16 X 1 1/2	219
		1602-16-16											-----	-----	---
1	-20	-----	2.50	2.82	3.00	2.062	1.031	1.00	---	-----	M42 x 2	---	-----	-----	---
		1602-16-20											-----	-----	---

ⓐ Order Separately

ⓑ The pressure rating of the assembly should not exceed the lower of the flange pad or the fitting. Check the fitting manufacturer for details.

MATERIAL : STEEL
1/07

Developers and Manufacturers of Hydraulic Flanges & Components

ISO 6149 THREADED IN-LINE FLANGES

SAE BOLT PATTERN

61 SERIES

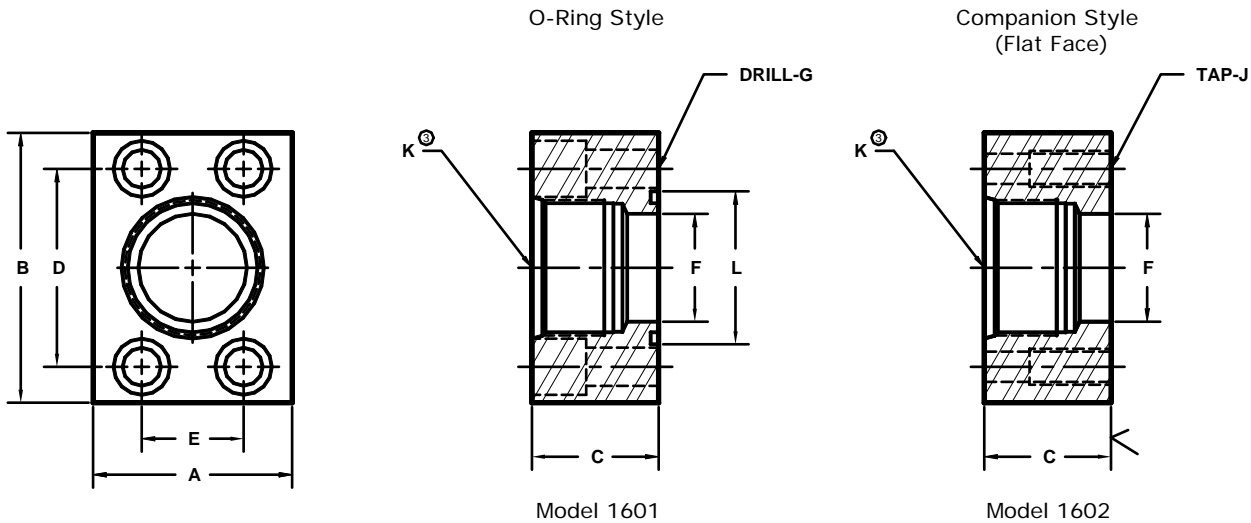

FLANGE SIZE	PORT SIZE	PART NUMBER	A	B	C	D	E	F	G	J	K	L	MOUNTING KIT ^①		
													PART NO.	BOLT SIZE	O-RING
1 1/4	-12	1601-20-12	2.50	3.19	1.50	2.312	1.188	.94	.47	----	M27 x 2	1.750	MK 1527	7/16-14 X 1 1/2	222
		1602-20-12							---	7/16-14		----	---		
1 1/4	-16	1601-20-16	2.50	3.19	1.50	2.312	1.188	1.20	.47	----	M33 x 2	1.750	MK 1527	7/16-14 X 1 1/2	222
		1602-20-16							---	7/16-14		----	---		
1 1/4	-20	1601-20-20	2.50	3.19	1.50	2.312	1.188	1.25	.47	----	M42 x 2	1.750	MK 1527	7/16-14 X 1 1/2	222
		1602-20-20							---	7/16-14		----	---		
1 1/4	-24	-----	3.00	3.19	3.00	2.312	1.188	1.25	---	----	M48 x 2	---	-----	-----	---
		1602-20-24							---	7/16-14		----	---		
1 1/2	-16	1601-24-16	2.75	3.75	1.75	2.750	1.406	1.20	.53	----	M33 x 2	2.125	MK 1547	1/2-13 X 1 3/4	225
		1602-24-16							---	1/2-13		----	---		
1 1/2	-20	1601-24-20	2.75	3.75	1.75	2.750	1.406	1.50	.53	----	M42 X 2	2.125	MK 1547	1/2-13 X 1 3/4	225
		1602-24-20							---	1/2-13		----	---		
1 1/2	-24	1601-24-24	2.75	3.75	1.75	2.750	1.406	1.50	.53	----	M48 x 2	2.125	MK 1547	1/2-13 X 1 3/4	225
		1602-24-24							---	1/2-13		----	---		
1 1/2	-32	-----	3.50	3.75	3.50	2.750	1.406	1.50	---	----	M60 x 2	---	-----	-----	---
		1602-24-32							---	1/2-13		----	---		
2	-20	1601-32-20	3.25	4.00	1.75	3.062	1.688	1.50	.53	----	M42 X 2	2.500	MK 582	1/2-13 X 1 3/4	228
		1602-32-20							---	1/2-13		----	---		
2	-24	1601-32-24	3.25	4.00	1.75	3.062	1.688	1.77	.53	----	M48 X 2	2.500	MK 582	1/2-13 X 1 3/4	228
		1602-32-24							---	1/2-13		----	---		
2	-32	1601-32-32	3.25	4.00	1.75	3.062	1.688	1.94	.53	----	M60 x 2	2.500	MK 582	1/2-13 X 1 3/4	228
		1602-32-32							---	1/2-13		----	---		
2 1/2 ^②	-20	1601-40-20	4.00	4.50	1.75	3.500	2.000	1.50	.53	----	M42 x 2	3.000	MK 1528	1/2-13 X 1 3/4	232
		1602-40-20							---	1/2-13		----	---		
2 1/2 ^②	-24	1601-40-24	4.00	4.50	1.75	3.500	2.000	1.77	.53	----	M48 x 2	3.000	MK 1528	1/2-13 X 1 3/4	232
		1602-40-24							---	1/2-13		----	---		
2 1/2 ^②	-32	1601-40-32	4.00	4.50	1.75	3.500	2.000	2.12	.53	----	M60 x 2	3.000	MK 1528	1/2-13 X 1 3/4	232
		1602-40-32							---	1/2-13		----	---		

① Order Separately ② 2500 PSI Max ③ The pressure rating of the assembly should not exceed the lower of the flange pad or the fitting. Check the fitting manufacturer for details. MATERIAL : STEEL 1/07