

Developers and Manufacturers of
Hydraulic Flanges & Components

BUTT WELD IN-LINE FLANGES

For Schedule 80 Pipe

| SAE BOLT PATTERN | | | 61 SERIES | | | | | | | | | | | | | WT | |
|--------------------|-----------|-------------|-----------|------|------|-------|-------|------|-----|-----|-------|------|-------|---------------------------|-----------------|-----|--------|
| FLANGE SIZE | PIPE SIZE | PART NUMBER | A | B | C | D | E | F | G | H | J | K | L | MOUNTING KIT ^① | | | |
| | | | | | | | | | | | | | | PART NO. | BOLT SIZE | | O-RING |
| 1/2 | 1/2 | 6109-08-08D | 1.50 | 2.12 | 1.25 | 1.500 | .688 | .53 | .34 | .38 | ----- | .88 | 1.000 | MK 512 | 5/16-18 X 1 1/2 | 210 | .7 |
| | | 6110-08-08D | | | | | | | --- | | | | | | | | |
| 3/4 | 3/4 | 6109-12-12D | 1.75 | 2.62 | 1.25 | 1.875 | .875 | .75 | .41 | .38 | ----- | 1.12 | 1.250 | MK 1525 | 3/8-16 X 1 1/2 | 214 | 1.0 |
| | | 6110-12-12D | | | | | | | --- | | | | | | | | |
| 1 | 1 | 6109-16-16D | 2.00 | 2.82 | 1.25 | 2.062 | 1.031 | .94 | .41 | .38 | ----- | 1.38 | 1.562 | MK 1542 | 3/8-16 X 1 1/2 | 219 | 1.2 |
| | | 6110-16-16D | | | | | | | --- | | | | | | | | |
| 1 1/4 | 1 1/4 | 6109-20-20D | 2.50 | 3.19 | 1.25 | 2.312 | 1.188 | 1.25 | .47 | .38 | ----- | 1.75 | 1.750 | MK 1527 | 7/16-14 X 1 1/2 | 222 | 1.6 |
| | | 6110-20-20D | | | | | | | --- | | | | | | | | |
| 1 1/2 | 1 1/2 | 6109-24-24D | 2.75 | 3.75 | 1.50 | 2.750 | 1.406 | 1.50 | .53 | .50 | ----- | 2.00 | 2.125 | MK 1547 | 1/2-13 X 1 3/4 | 225 | 2.3 |
| | | 6110-24-24D | | | | | | | --- | | | | | | | | |
| 2 | 2 | 6109-32-32D | 3.25 | 4.00 | 1.50 | 3.062 | 1.688 | 1.94 | .53 | .50 | ----- | 2.50 | 2.500 | MK 582 | 1/2-13 X 1 3/4 | 228 | 2.8 |
| | | 6110-32-32D | | | | | | | --- | | | | | | | | |
| 2 1/2 ^② | 2 1/2 | 6109-40-40D | 4.00 | 4.50 | 1.75 | 3.500 | 2.000 | 2.32 | .53 | .50 | ----- | 3.00 | 3.000 | MK 561 | 1/2-13 X 2 | 232 | 4.8 |
| | | 6110-40-40D | | | | | | | --- | | | | | | | | |
| 3 ^③ | 3 | 6109-48-48D | 4.50 | 5.31 | 2.00 | 4.188 | 2.438 | 2.90 | .66 | .50 | ----- | 3.50 | 3.625 | MK 585 | 5/8-11 X 2 1/2 | 237 | 7.2 |
| | | 6110-48-48D | | | | | | | --- | | | | | | | | |
| 3 1/2 ^④ | 3 1/2 | 6109-56-56D | 5.00 | 6.00 | 1.50 | 4.750 | 2.750 | 3.36 | .66 | .50 | ----- | 4.00 | 4.109 | MK 1571 | 5/8-11 X 2 | 241 | 5.9 |
| | | 6110-56-56D | | | | | | | --- | | | | | | | | |
| 4 ^④ | 4 | 6109-64-64D | 5.50 | 6.38 | 1.50 | 5.125 | 3.062 | 3.83 | .66 | .50 | ----- | 4.50 | 4.609 | MK 1572 | 5/8-11 X 2 | 245 | 6.7 |
| | | 6110-64-64D | | | | | | | --- | | | | | | | | |
| 5 ^④ | 5 | 6109-80-80D | 7.00 | 7.25 | 2.00 | 6.000 | 3.625 | 4.81 | .66 | .50 | ----- | 5.62 | 5.609 | MK 1573 | 5/8-11 X 2 1/2 | 253 | 14.3 |
| | | 6110-80-80D | | | | | | | --- | | | | | | | | |

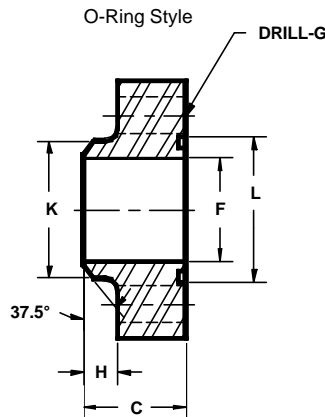
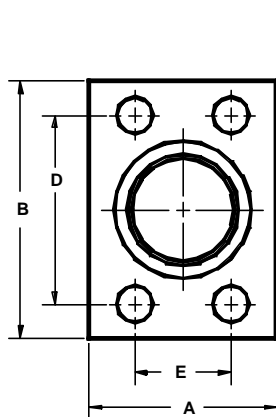

Model 6109 / 6111

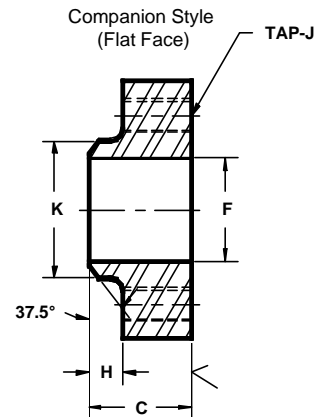

Model 6110 / 6112

| SAE BOLT PATTERN | | | 62 SERIES | | | | | | | | | | | | | WT | |
|--------------------|-----------|-------------|-----------|------|------|-------|-------|------|------|-----|-------|------|-------|---------------------------|-----------------|-----|--------|
| FLANGE SIZE | PIPE SIZE | PART NUMBER | A | B | C | D | E | F | G | H | J | K | L | MOUNTING KIT ^① | | | |
| | | | | | | | | | | | | | | PART NO. | BOLT SIZE | | O-RING |
| 1/2 | 1/2 | 6111-08-08D | 1.75 | 2.22 | 1.25 | 1.594 | .718 | .53 | .34 | .38 | ----- | .88 | 1.000 | MK 512 | 5/16-18 X 1 1/2 | 210 | .8 |
| | | 6112-08-08D | | | | | | | --- | | | | | | | | |
| 3/4 | 3/4 | 6111-12-12D | 2.00 | 2.81 | 1.25 | 2.000 | .937 | .75 | .41 | .38 | ----- | 1.12 | 1.250 | MK 1525 | 3/8-16 X 1 1/2 | 214 | 1.3 |
| | | 6112-12-12D | | | | | | | --- | | | | | | | | |
| 1 | 1 | 6111-16-16D | 2.25 | 3.19 | 1.25 | 2.250 | 1.093 | .94 | .47 | .38 | ----- | 1.38 | 1.562 | MK 513 | 7/16-14 X 1 3/4 | 219 | 1.5 |
| | | 6112-16-16D | | | | | | | --- | | | | | | | | |
| 1 1/4 | 1 1/4 | 6111-20-20D | 2.75 | 3.75 | 1.25 | 2.625 | 1.250 | 1.25 | .53 | .38 | ----- | 1.75 | 1.750 | MK 529 | 1/2-13 X 1 3/4 | 222 | 2.1 |
| | | 6112-20-20D | | | | | | | --- | | | | | | | | |
| 1 1/2 | 1 1/2 | 6111-24-24D | 3.25 | 4.50 | 1.50 | 3.125 | 1.437 | 1.50 | .66 | .50 | ----- | 2.00 | 2.125 | MK 562 | 5/8-11 X 2 | 225 | 3.3 |
| | | 6112-24-24D | | | | | | | --- | | | | | | | | |
| 2 | 2 | 6111-32-32D | 4.00 | 5.25 | 1.75 | 3.812 | 1.750 | 1.94 | .78 | .50 | ----- | 2.50 | 2.500 | MK 1548 | 3/4-10 X 2 1/2 | 228 | 5.9 |
| | | 6112-32-32D | | | | | | | --- | | | | | | | | |
| 2 1/2 ^⑤ | 2 1/2 | 6111-40-40D | 5.00 | 6.88 | 2.00 | 4.875 | 2.312 | 2.32 | .94 | .50 | ----- | 3.00 | 3.000 | MK 1575 | 7/8-9 X 2 3/4 | 232 | 12.0 |
| | | 6112-40-40D | | | | | | | --- | | | | | | | | |
| 3 ^⑤ | 3 | 6111-48-48D | 6.00 | 8.50 | 2.50 | 6.000 | 2.812 | 2.90 | 1.19 | .50 | ----- | 3.50 | 3.625 | MK 1776 | 1 1/8-7 X 4 | 237 | 23.3 |
| | | 6112-48-48D | | | | | | | --- | | | | | | | | |

① Order Separately ② 2500 PSI Max ③ 2000 PSI Max ④ 500 PSI Max ⑤ Not included in SAE J518 specifications MATERIAL : 316L STAINLESS STEEL 10/00