

Developers and Manufacturers of Hydraulic Flanges & Components

SOCKET WELD IN-LINE TUBE FLANGES

SAE BOLT PATTERN

61 SERIES

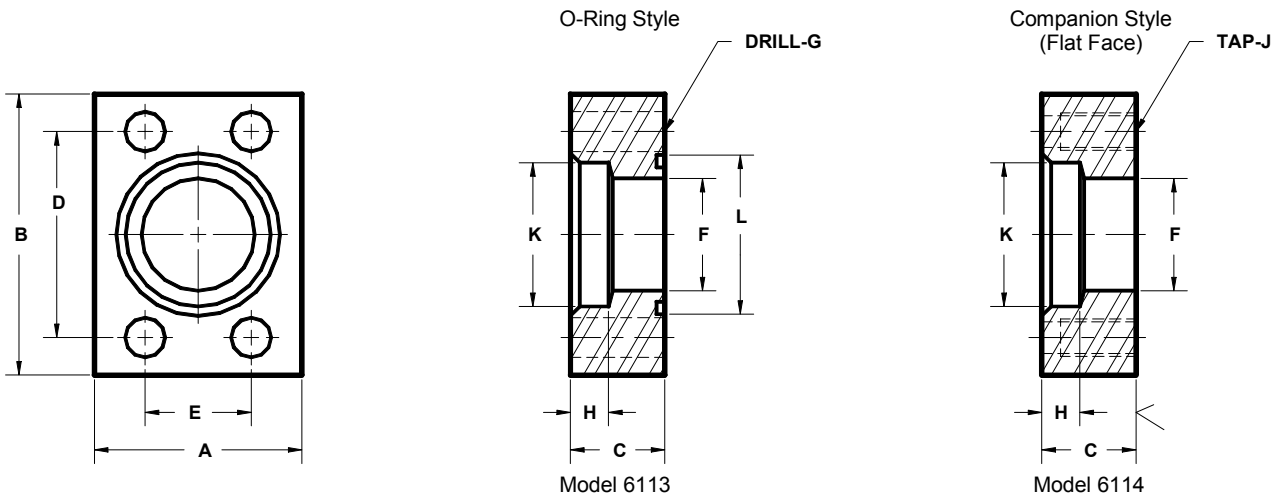

FLANGE SIZE	TUBE SIZE	PART NUMBER	A	B	C	D	E	F	G _{mm}	H	J _{mm}	K	L	MOUNTING KIT ^①			WT
														PART NO.	BOLT SIZE	O-RING	
1/2	1/2	6113-08-08BM8	1.50	2.12	.75	1.500	.688	.38	8.5	.38	----	.510	1.000	MKM 501	M8 x 30	210	.7
		---							M8 x 1.25		---						
1/2	3/4	6113-08-12BM8	1.50	2.12	.75	1.500	.688	.50	8.5	.38	----	.760	1.000	MKM 501	M8 x 30	210	.6
		---							M8 x 1.25		---						
3/4	3/4	6113-12-12BM10	1.75	2.62	1.00	1.875	.875	.50	10.5	.50	----	.760	1.250	MKM 502	M10 x 40	214	1.2
		---							M10x 1.5		---						
3/4	7/8	6113-12-14BM10	1.75	2.62	1.00	1.875	.875	.75	10.5	.50	----	.885	1.250	MKM 502	M10 x 40	214	1.1
		---							M10 x 1.5		---						
3/4	1	6113-12-16BM10	1.75	2.62	1.00	1.875	.875	.75	10.5	.50	----	1.010	1.250	MKM 502	M10 x 40	214	1.0
		---							M10 x 1.5		---						
1	1	6113-16-16BM10	2.00	2.82	1.00	2.062	1.031	.75	10.5	.50	----	1.010	1.562	MKM 503	M10 x 40	219	1.4
		---							M10 x 1.5		---						
1	1 1/4	6113-16-20BM10	2.00	2.82	1.00	2.062	1.031	1.00	10.5	.50	----	1.260	1.562	MKM 503	M10 x 40	219	1.2
		---							M10 x 1.5		---						
1 1/4	1 1/4	6113-20-20BM10	2.50	3.19	1.00	2.312	1.188	1.00	10.5	.50	----	1.260	1.750	MKM 3524	M10 x 40	222	2.0
		---							M10 x 1.5		---						
1 1/4	1 1/2	6113-20-24BM10	2.50	3.19	1.00	2.312	1.188	1.25	10.5	.50	----	1.510	1.750	MKM 3524	M10 x 40	222	1.7
		---							M10 x 1.5		---						
1 1/2	1 1/2	6113-24-24BM12	2.75	3.75	1.25	2.750	1.406	1.25	13.0	.50	----	1.510	2.125	MKM 3596	M12 x 50	225	2.7
		---							M12 x 1.75		---						
1 1/2	1 3/4	6113-24-28BM12	2.75	3.75	1.25	2.750	1.406	1.50	13.0	.50	----	1.760	2.125	MKM 3596	M12 x 50	225	2.5
		---							M12 x 1.75		---						
1 1/2	2	6113-24-32BM12	2.75	3.75	1.25	2.750	1.406	1.50	13.0	.50	----	2.010	2.125	MKM 3596	M12 x 50	225	2.3
		---							M12 x 1.75		---						
2	2	6113-32-32BM12	3.25	4.00	1.50	3.062	1.688	1.50	13.0	.50	----	2.010	2.500	MKM 3501	M12 x 55	228	4.0
		---							M12 x 1.75		---						
2	2 1/4	6113-32-36BM12	3.25	4.00	1.50	3.062	1.688	1.94	13.0	.50	----	2.260	2.500	MKM 3501	M12 x 55	228	3.5
		---							M12 x 1.75		---						

① Order Separately

MATERIAL : 304L STAINLESS STEEL

NOTE: DIMENSIONS ARE IN INCHES UNLESS OTHERWISE NOTED.

7/01