

Developers and Manufacturers of  
Hydraulic Flanges & Components

## SOCKET WELD IN-LINE TUBE FLANGES

SAE BOLT PATTERN

62 SERIES

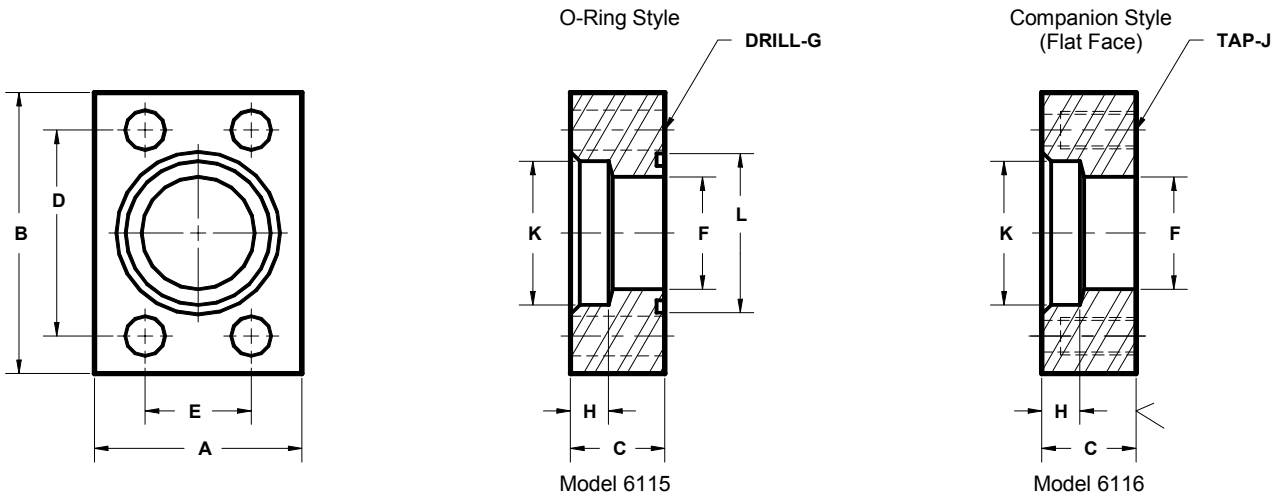

FLANGE SIZE	TUBE SIZE	PART NUMBER	A	B	C	D	E	F	G	H	J	K	L	MOUNTING KIT <sup>①</sup>			WT
														PART NO.	BOLT SIZE	O-RING	
1/2	1/2	6115-08-08D	1.75	2.22	1.00	1.594	.718	.38	.34	.50	-----	.510	1.000	MK 512	5/16-18 X 1 1/2	210	.9
		6116-08-08D												-----	-----	---	
1/2	3/4	6115-08-12D	1.75	2.22	1.00	1.594	.718	.50	.34	.50	-----	.760	1.000	MK 512	5/16-18 X 1 1/2	210	.8
		6116-08-12D												-----	-----	---	
3/4	3/4	6115-12-12D	2.00	2.81	1.00	2.000	.937	.50	.41	.50	-----	.760	1.250	MK 502	3/8-16 X 1 3/4	214	1.4
		6116-12-12D												-----	-----	---	
3/4	7/8	6115-12-14D	2.00	2.81	1.00	2.000	.937	.75	.41	.50	-----	.885	1.250	MK 502	3/8-16 X 1 3/4	214	1.3
		6116-12-14D												-----	-----	---	
3/4	1	6115-12-16D	2.00	2.81	1.00	2.000	.937	.75	.41	.50	-----	1.010	1.250	MK 502	3/8-16 X 1 3/4	214	1.2
		6116-12-16D												-----	-----	---	
1	1	6115-16-16D	2.25	3.19	1.00	2.250	1.093	.75	.47	.50	-----	1.010	1.562	MK 513	7/16-14 X 1 3/4	219	1.7
		6116-16-16D												-----	-----	---	
1	1 1/4	6115-16-20D	2.25	3.19	1.00	2.250	1.093	1.00	.47	.50	-----	1.260	1.562	MK 513	7/16-14 X 1 3/4	219	1.5
		6116-16-20D												-----	-----	---	
1 1/4	1 1/4	6115-20-20D	2.75	3.75	1.25	2.625	1.250	1.00	.53	.50	-----	1.260	1.750	MK 514	1/2-13 X 2 1/4	222	3.0
		6116-20-20D												-----	-----	---	
1 1/4	1 1/2	6115-20-24D	2.75	3.75	1.25	2.625	1.250	1.25	.53	.50	-----	1.510	1.750	MK 514	1/2-13 X 2 1/4	222	2.7
		6116-20-24D												-----	-----	---	
1 1/2	1 1/2	6115-24-24D	3.25	4.50	1.50	3.125	1.447	1.25	.66	.50	-----	1.510	2.125	MK 515	5/8-11 X 2 1/2	225	5.1
		6116-24-24D												-----	-----	---	
1 1/2	1 3/4	6115-24-28D	3.25	4.50	1.50	3.125	1.437	1.50	.66	.50	-----	1.760	2.125	MK 515	5/8-11 X 2 1/2	225	4.9
		6116-24-28D												-----	-----	---	
1 1/2	2	6115-24-32D	3.25	4.50	1.50	3.125	1.437	1.50	.66	.50	-----	2.010	2.125	MK 515	5/8-11 X 2 1/2	225	4.7
		6116-24-32D												-----	-----	---	
2	2	6115-32-32D	4.00	5.25	1.75	3.812	1.750	1.50	.78	.62	-----	2.010	2.500	MK 516	3/4-10 X 3	228	8.0
		6116-32-32D												-----	-----	---	
2	2 1/4	6115-32-36D	4.00	5.25	1.75	3.812	1.750	1.94	.78	.62	-----	2.260	2.500	MK 516	3/4-10 X 3	228	7.5
		6116-32-36D												-----	-----	---	

① Order Separately

MATERIAL : 316L STAINLESS STEEL

10/00