

Developers and Manufacturers of Hydraulic Flanges & Components

BUTT WELD IN-LINE FLANGES

For Schedule 160 Pipe

SAE BOLT PATTERN										61 SERIES							
FLANGE SIZE	PIPE SIZE	PART NUMBER	A	B	C	D	E	F	G _{mm}	H	J _{mm}	K	L	MOUNTING KIT ^①			WT
														PART NO.	BOLT SIZE	O-RING	
1/2	1/2	6117-08-08BM8	1.50	2.12	1.25	1.500	.688	.47	8.5	.38	-----	.88	1.000	MKM 512	M8 x 35	210	.7

3/4	3/4	6117-12-12BM10	1.75	2.62	1.25	1.875	.875	.61	8.5	.38	-----	1.12	1.250	MKM 1525	M10 x 35	214	.9

1	1	6117-16-16BM10	2.00	2.82	1.25	2.062	1.031	.81	10.5	.38	-----	1.38	1.562	MKM 1542	M10 x 35	219	1.2

1 1/4	1 1/4	6117-20-20BM10	2.50	3.19	1.25	2.312	1.188	1.16	10.5	.38	-----	1.75	1.750	MKM 4520	M10 x 35	222	1.6

1 1/2	1 1/2	6117-24-24BM12	2.75	3.75	1.50	2.750	1.406	1.34	13.0	.50	-----	2.00	2.125	MKM 4551	M12 x 40	225	2.4

2	2	6117-32-32BM12	3.25	4.00	1.50	3.062	1.688	1.69	13.0	.50	-----	2.50	2.500	MKM 4552	M12 x 45	228	3.0

2 1/2 ^②	2 1/2	6117-40-40BM12	4.00	4.50	1.75	3.500	2.000	2.12	13.0	.50	-----	3.00	3.000	MKM 2575	M12 x 50	232	5.1

3 ^③	3	6117-48-48BM16	4.50	5.31	2.00	4.188	2.438	2.62	17.0	.50	-----	3.50	3.625	MKM 585	M16 x 60	237	7.7

3 1/2 ^④	3 1/2	6117-56-56BM16	5.00	6.00	1.50	4.750	2.750	3.00	17.0	.50	-----	4.00	4.109	MKM 1571	M16 x 50	241	6.6

4 ^④	4	6117-64-64BM16	5.50	6.38	1.50	5.125	3.062	3.44	17.0	.50	-----	4.50	4.609	MKM 1572	M16 x 50	245	7.4

5 ^④	5	6117-80-80BM16	7.00	7.25	2.00	6.000	3.625	4.31	17.0	.50	-----	5.62	5.609	MKM 1573	M16 x 60	253	15.2

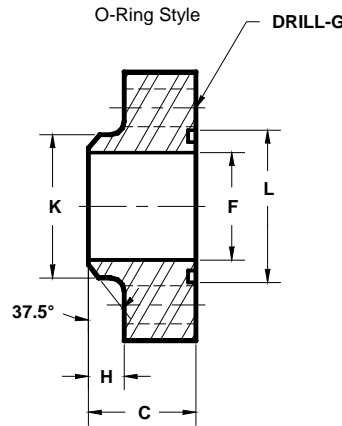
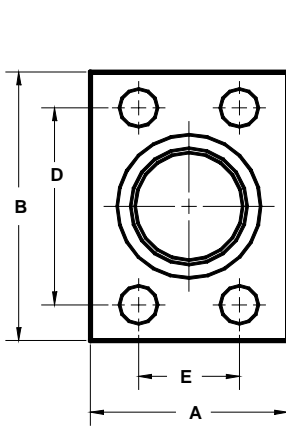

Model 6117 / 6119

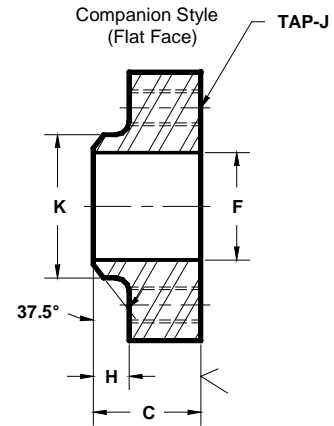

Model 6118 / 6120

SAE BOLT PATTERN										62 SERIES							
FLANGE SIZE	PIPE SIZE	PART NUMBER	A	B	C	D	E	F	G _{mm}	H	J _{mm}	K	L	MOUNTING KIT ^①			WT
														PART NO.	BOLT SIZE	O-RING	
1/2	1/2	6119-08-08BM8	1.75	2.22	1.25	1.594	.718	.47	8.5	.38	-----	.88	1.000	MKM 512	M8 x 35	210	.9

3/4	3/4	6119-12-12BM10	2.00	2.81	1.25	2.000	.937	.61	10.5	.38	-----	1.12	1.250	MKM 1525	M10 x 35	214	1.3

1	1	6119-16-16BM12	2.25	3.19	1.25	2.250	1.093	.81	12.5	.38	-----	1.38	1.562	MKM 4569	M12 x 40	219	1.5

1 1/4	1 1/4	6119-20-20BM12	2.75	3.75	1.25	2.625	1.250	1.16	13.0	.38	-----	1.75	1.750	MKM 1527	M12 x 40	222	2.2

1 1/2	1 1/2	6119-24-24BM16	3.25	4.50	1.50	3.125	1.437	1.34	17.0	.50	-----	2.00	2.125	MKM 562	M16 x 45	225	3.6

2	2	6119-32-32BM20	4.00	5.25	1.75	3.812	1.750	1.69	21.0	.50	-----	2.50	2.500	MKM 1548	M20 x 60	228	6.3

2 1/2 ^⑤	2 1/2	6119-40-40BM24	5.00	6.88	2.00	4.875	2.312	2.12	25.5	.50	-----	3.00	3.000	MKM 1575	M24 x 70	232	12.6

3 ^⑤	3	6119-48-48BM30	6.00	8.50	2.50	6.000	2.812	2.62	32.0	.50	-----	3.50	3.625	MKM 1576	M30 x 100	237	23.9

① Order Separately ② 2500 PSI Max ③ 2000 PSI Max ④ 500 PSI Max ⑤ Not included in SAE J518 specifications MATERIAL : 304L STAINLESS STEEL
NOTE: DIMENSIONS ARE IN INCHES UNLESS OTHERWISE NOTED. 9/04