

Developers and Manufacturers of  
Hydraulic Flanges & Components

## SOCKET WELD ELBOW FLANGES

SAE BOLT PATTERN										61 SERIES							WT	
FLANGE SIZE	PIPE SIZE	PART NUMBER	A	B	C	D	E	F	G	H <sub>1</sub>	H <sub>2</sub>	J	K	L	MOUNTING KIT <sup>①</sup>			
															PART NO.	BOLT SIZE		O-RING
1/2	1/2	6125-08-08D	1.75	2.12	1.44	1.500	.688	.50	.34	.38	.75	-----	.860	1.000	MK 541	5/16-18 X 2	210	1.3
		6126-08-08D							---									
3/4	3/4	6125-12-12D	2.00	2.62	1.70	1.875	.875	.75	.41	.50	.88	-----	1.070	1.250	MK 542	3/8-16 X 2 1/2	214	2.0
		6126-12-12D							---									
1	1	6125-16-16D	2.25	2.82	1.94	2.062	1.031	1.00	.41	.50	1.00	-----	1.335	1.562	MK 543	3/8-16 X 2 3/4	219	2.7
		6126-16-16D							---									
1 1/4	1 1/4	6125-20-20D	2.75	3.19	2.40	2.312	1.188	1.25	.47	.50	1.25	-----	1.680	1.750	MK 578	7/16-14 X 3 1/4	222	4.8
		6126-20-20D							---									
1 1/2	1 1/2	6125-24-24D	3.00	3.75	2.90	2.750	1.406	1.50	.53	.50	1.38	-----	1.920	2.125	MK 545	1/2-13 X 4	225	7.3
		6126-24-24D							---									
2	2	6125-32-32D	3.50	4.00	3.40	3.062	1.688	1.94	.53	.50	1.62	-----	2.411	2.500	MK 546	1/2-13 X 4 1/2	228	9.9
		6126-32-32D							---									
2 1/2 <sup>②</sup>	2 1/2	6125-40-40D	4.00	4.50	3.96	3.500	2.000	2.44	.53	.62	2.00	-----	2.911	3.000	MK 547	1/2-13 X 5	232	13.9
		6126-40-40D							---									
3 <sup>③</sup>	3	6125-48-48D	5.00	5.31	4.96	4.188	2.438	2.94	.66	.62	2.25	-----	3.540	3.625	MK 548	5/8-11 X 6	237	24.9
		6126-48-48D							---									
3 1/2 <sup>④</sup>	3 1/2	6125-56-56D	5.50	6.00	5.40	4.750	2.750	3.44	.66	.62	2.50	-----	4.045	4.109	MK 549	5/8-11 X 6 1/2	241	34.8
		6126-56-56D							---									
4 <sup>④</sup>	4	6125-64-64D	6.00	6.38	5.96	5.125	3.062	3.94	.66	.62	2.75	-----	4.550	4.609	MK 550	5/8-11 X 7	245	41.9
		6126-64-64D							---									
5 <sup>④</sup>	5	6125-80-80D	7.00	7.25	6.90	6.000	3.625	4.94	.66	.62	3.38	-----	5.635	5.609	MK 1569	5/8-11 X 8	253	60.9
		6126-80-80D							---									

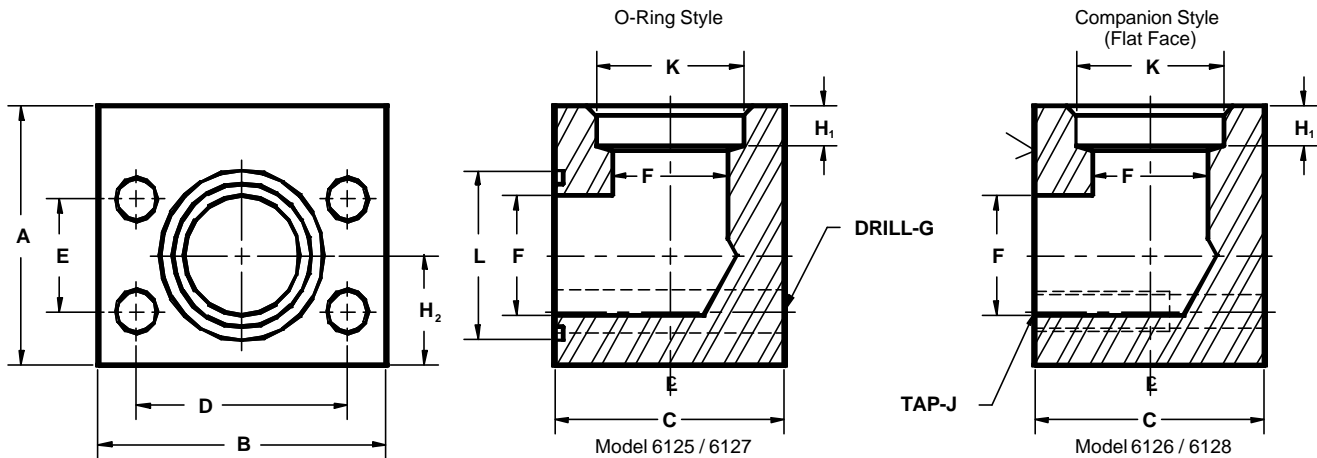

SAE BOLT PATTERN										62 SERIES							WT	
FLANGE SIZE	PIPE SIZE	PART NUMBER	A	B	C	D	E	F	G	H <sub>1</sub>	H <sub>2</sub>	J	K	L	MOUNTING KIT <sup>①</sup>			
															PART NO.	BOLT SIZE		O-RING
1/2	1/2	6127-08-08D	2.00	2.22	1.46	1.594	.718	.50	.34	.38	.88	-----	.860	1.000	MK 541	5/16-18 X 2	210	1.6
		6128-08-08D							---									
3/4	3/4	6127-12-12D	2.25	2.81	1.70	2.000	.937	.75	.41	.50	1.00	-----	1.070	1.250	MK 542	3/8-16 X 2 1/2	214	2.6
		6128-12-12D							---									
1	1	6127-16-16D	2.50	3.19	2.21	2.250	1.093	1.00	.47	.50	1.12	-----	1.335	1.562	MK 2533	7/16-14 X 3	219	4.1
		6128-16-16D							---									
1 1/4	1 1/4	6127-20-20D	3.00	3.75	2.44	2.625	1.250	1.25	.53	.50	1.38	-----	1.680	1.750	MK 552	1/2-13 X 3 1/4	222	6.3
		6128-20-20D							---									
1 1/2	1 1/2	6127-24-24D	3.50	4.50	2.96	3.125	1.437	1.50	.66	.50	1.62	-----	1.920	2.125	MK 553	5/8-11 X 4	225	10.7
		6128-24-24D							---									
2	2	6127-32-32D	4.00	5.25	3.46	3.812	1.750	1.94	.78	.50	2.00	-----	2.411	2.500	MK 554	3/4-10 X 4 1/2	228	15.9
		6128-32-32D							---									
2 1/2 <sup>⑤</sup>	2 1/2	6127-40-40D	5.50	6.88	4.50	4.875	2.312	2.44	.94	.62	2.50	-----	2.911	3.000	MK 2557	7/8-9 X 6	232	38.6
		6128-40-40D							---									
3 <sup>⑤</sup>	3	6127-48-48D	6.00	8.50	5.00	6.000	2.812	2.94	1.19	.62	3.00	-----	3.540	3.625	MK 756	1 1/8-7 X 7	237	56.5
		6128-48-48D							---									

① Order Separately    ② 2500 PSI Max    ③ 2000 PSI Max    ④ 500 PSI Max    ⑤ Not included in SAE J518 specifications    MATERIAL: 316L STAINLESS STEEL 10/00