

Developers and Manufacturers of Hydraulic Flanges & Components

BUTT WELD ELBOW FLANGES

For Schedule 80 Pipe

SAE BOLT PATTERN										61 SERIES									
FLANGE SIZE	PIPE SIZE	PART NUMBER	A	B	C	D	E	F	Gmm	H ₁	H ₂	Jmm	K	L	MOUNTING KIT ^①			WT	
															PART NO.	BOLT SIZE	O-RING		
1/2	1/2	6137-08-08BM8	2.00	2.12	1.44	1.500	.688	.53	8.5	.38	.75	-----	.88	1.000	MKM 541	M8 x 50	210	1.3	
		6138-08-08BM8													-----	-----	-----		
3/4	3/4	6137-12-12BM10	2.25	2.62	1.70	1.875	.875	.75	10.5	.38	.88	-----	1.12	1.250	MKM 542	M10 x 60	214	2.0	
		6138-12-12BM10													-----	-----	-----		
1	1	6137-16-16BM10	2.50	2.82	1.94	2.062	1.031	.94	10.5	.38	1.00	-----	1.38	1.562	MKM 543	M10 x 65	219	2.7	
		6138-16-16BM10													-----	-----	-----		
1 1/4	1 1/4	6137-20-20BM10	3.00	3.19	2.40	2.312	1.188	1.25	10.5	.38	1.25	-----	1.75	1.750	MKM 4532	M10 x 75	222	4.0	
		6138-20-20BM10													-----	-----	-----		
1 1/2	1 1/2	6137-24-24BM12	3.25	3.75	2.90	2.750	1.406	1.50	13.0	.50	1.38	-----	2.00	2.125	MKM 4533	M12 x 90	225	7.0	
		6138-24-24BM12													-----	-----	-----		
2	2	6137-32-32BM12	3.75	4.00	3.40	3.062	1.688	1.94	13.0	.50	1.62	-----	2.50	2.500	MKM 4534	M12 x 100	228	9.5	
		6138-32-32BM12													-----	-----	-----		
2 1/2 ^②	2 1/2	6137-40-40BM12	4.50	4.50	3.96	3.500	2.000	2.32	13.0	.50	2.00	-----	3.00	3.000	MKM 4535	M12 x 120	232	15.0	
		6138-40-40BM12													-----	-----	-----		
3 ^③	3	6137-48-48BM16	5.00	5.31	4.96	4.188	2.438	2.90	17.0	.50	2.25	-----	3.50	3.625	MKM 548	M16 x 150	237	27.2	
		6138-48-48BM16													-----	-----	-----		
3 1/2 ^④	3 1/2	6137-56-56BM16	5.50	6.00	5.40	4.750	2.750	3.36	17.0	.50	2.50	-----	4.00	4.109	MKM 549	M16 x 160	241	37.0	
		6138-56-56BM16													-----	-----	-----		
4 ^④	4	6137-64-64BM16	6.00	6.38	5.96	5.125	3.062	3.83	17.0	.50	2.75	-----	4.50	4.609	MKM 550	M16 x 180	245	48.0	
		6138-64-64BM16													-----	-----	-----		
5 ^④	5	6137-80-80BM16	7.50	7.25	6.90	6.000	3.625	4.81	17.0	.50	3.38	-----	5.62	5.609	MKM 1569	M16 x 200	253	61.4	
		6138-80-80BM16													-----	-----	-----		

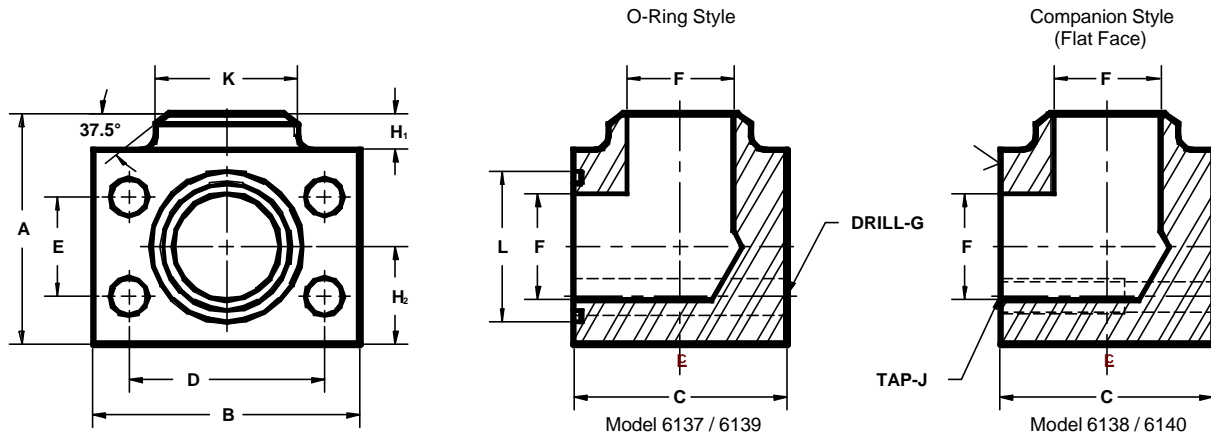

SAE BOLT PATTERN										62 SERIES									
FLANGE SIZE	PIPE SIZE	PART NUMBER	A	B	C	D	E	F	Gmm	H ₁	H ₂	Jmm	K	L	MOUNTING KIT ^①			WT	
															PART NO.	BOLT SIZE	O-RING		
1/2	1/2	6139-08-08BM8	2.25	2.22	1.46	1.594	.718	.53	8.5	.38	.88	-----	.88	1.000	MKM 541	M8 x 50	210	1.5	
		6140-08-08BM8													-----	-----	-----		
3/4	3/4	6139-12-12BM10	2.50	2.81	1.70	2.000	.937	.75	10.5	.38	1.00	-----	1.12	1.250	MKM 542	M10 x 60	214	2.5	
		6140-12-12BM10													-----	-----	-----		
1	1	6139-16-16BM12	2.75	3.19	2.21	2.250	1.093	.94	12.5	.38	1.12	-----	1.38	1.562	MKM 2533	M12 x 75	219	4.2	
		6140-16-16BM12													-----	-----	-----		
1 1/4	1 1/4	6139-20-20BM12	3.25	3.75	2.44	2.625	1.250	1.25	13.0	.38	1.38	-----	1.75	1.750	MKM 578	M12 x 80	222	6.3	
		6140-20-20BM12													-----	-----	-----		
1 1/2	1 1/2	6139-24-24BM16	3.75	4.50	2.96	3.125	1.437	1.50	17.0	.50	1.62	-----	2.00	2.125	MKM 553	M16 x 100	225	10.0	
		6140-24-24BM16													-----	-----	-----		
2	2	6139-32-32BM20	4.50	5.25	3.46	3.812	1.750	1.94	21.0	.50	2.00	-----	2.50	2.500	MKM 554	M20 x 120	228	15.0	
		6140-32-32BM20													-----	-----	-----		
2 1/2 ^⑤	2 1/2	6139-40-40BM24	5.50	6.88	4.50	4.875	2.312	2.32	25.5	.50	2.50	-----	3.00	3.000	MKM 2557	M24 x 150	232	33.2	
		6140-40-40BM24													-----	-----	-----		
3 ^⑤	3	6139-48-48BM30	6.50	8.50	5.00	6.000	2.812	2.90	32.0	.50	3.00	-----	3.50	3.625	MKM 756	M30 x 180	237	48.0	
		6140-48-48BM30													-----	-----	-----		

① Order Separately ② 2500 PSI Max ③ 2000 PSI Max ④ 500 PSI Max ⑤ Not included in SAE J518 specifications MATERIAL : 304L STAINLESS STEEL
NOTE: DIMENSIONS ARE IN INCHES UNLESS OTHERWISE NOTED. 9/01