

Developers and Manufacturers of  
Hydraulic Flanges & Components

## BUTT WELD ELBOW FLANGES

For Schedule 160 Pipe

SAE BOLT PATTERN			61 SERIES													WT			
FLANGE SIZE	PIPE SIZE	PART NUMBER	A	B	C	D	E	F <sub>1</sub>	F <sub>2</sub>	G	H <sub>1</sub>	H <sub>2</sub>	J	K	L		MOUNTING KIT <sup>①</sup>		
																PART NO.	BOLT SIZE	O-RING	
1/2	1/2	6141-08-08D	2.00	2.12	1.44	1.500	.688	.53	.47	.34	.38	.75	-----	.88	1.000	MK 541	5/16-18 X 2	210	1.3
		6142-08-08D								---					5/16-18				
3/4	3/4	6141-12-12D	2.25	2.62	1.70	1.875	.875	.75	.61	.41	.38	.88	-----	1.12	1.250	MK 542	3/8-16 X 2 1/2	214	2.2
		6142-12-12D								---					3/8-16				
1	1	6141-16-16D	2.50	2.82	1.94	2.062	1.031	.94	.81	.41	.38	1.00	-----	1.38	1.562	MK 543	3/8-16 X 2 3/4	219	2.9
		6142-16-16D								---					3/8-16				
1 1/4	1 1/4	6141-20-20D	3.00	3.19	2.40	2.312	1.188	1.25	1.16	.47	.38	1.25	-----	1.75	1.750	MK 578	7/16-14 X 3 1/4	222	4.8
		6142-20-20D								---					7/16-14				
1 1/2	1 1/2	6141-24-24D	3.25	3.75	2.90	2.750	1.406	1.50	1.34	.53	.50	1.38	-----	2.00	2.125	MK 545	1/2-13 X 4	225	7.3
		6142-24-24D								---					1/2-13				
2	2	6141-32-32D	3.75	4.00	3.40	3.062	1.688	1.94	1.69	.53	.50	1.62	-----	2.50	2.500	MK 546	1/2-13 X 4 1/2	228	9.7
		6142-32-32D								---					1/2-13				
2 1/2 <sup>②</sup>	2 1/2	6141-40-40D	4.50	4.50	3.96	3.500	2.000	2.32	2.12	.53	.50	2.00	-----	3.00	3.000	MK 547	1/2-13 X 5	232	15.9
		6142-40-40D								---					1/2-13				
3 <sup>③</sup>	3	6141-48-48D	5.00	5.31	4.96	4.188	2.438	2.90	2.62	.66	.50	2.25	-----	3.50	3.625	MK 548	5/8-11 X 6	237	23.8
		6142-48-48D								---					5/8-11				
3 1/2 <sup>④</sup>	3 1/2	6141-56-56D	5.50	6.00	5.40	4.750	2.750	3.36	3.00	.66	.50	2.50	-----	4.00	4.109	MK 549	5/8-11 X 6 1/2	241	34.1
		6142-56-56D								---					5/8-11				
4 <sup>④</sup>	4	6141-64-64D	6.00	6.38	5.96	5.125	3.062	3.83	3.44	.66	.50	2.75	-----	4.50	4.609	MK 550	5/8-11 X 7	245	41.2
		6142-64-64D								---					5/8-11				
5 <sup>④</sup>	5	6141-80-80D	7.50	7.25	6.90	6.000	3.625	4.81	4.31	.66	.50	3.38	-----	5.62	5.609	MK 1569	5/8-11 X 8	253	60.2
		6142-80-80D								---					5/8-11				

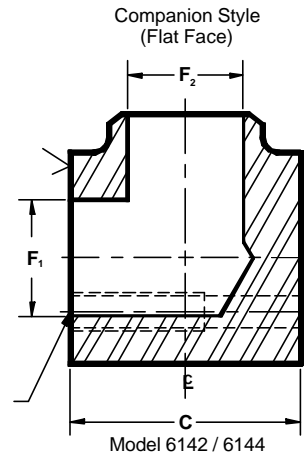
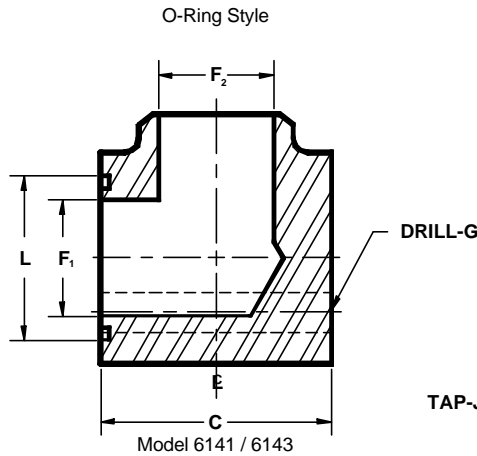
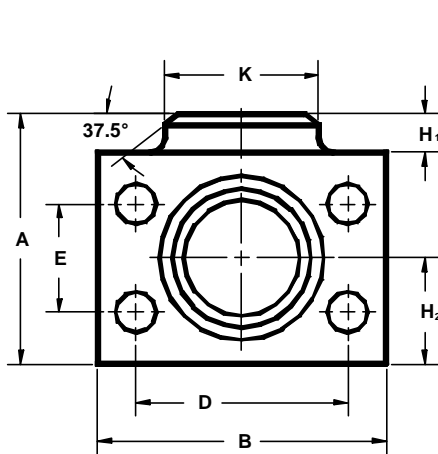

SAE BOLT PATTERN			62 SERIES													WT			
FLANGE SIZE	PIPE SIZE	PART NUMBER	A	B	C	D	E	F <sub>1</sub>	F <sub>2</sub>	G	H <sub>1</sub>	H <sub>2</sub>	J	K	L		MOUNTING KIT <sup>①</sup>		
																PART NO.	BOLT SIZE	O-RING	
1/2	1/2	6143-08-08D	2.25	2.22	1.46	1.594	.718	.53	.47	.34	.38	.88	-----	.88	1.000	MK 541	5/16-18 X 2	210	1.6
		6144-08-08D								---					5/16-18				
3/4	3/4	6143-12-12D	2.50	2.81	1.70	2.000	.937	.75	.61	.41	.38	1.00	-----	1.12	1.250	MK 542	3/8-16 X 2 1/2	214	2.6
		6144-12-12D								---					3/8-16				
1	1	6143-16-16D	2.75	3.19	2.21	2.250	1.093	.94	.81	.47	.38	1.12	-----	1.38	1.562	MK 2533	7/16-14 X 3	219	4.2
		6144-16-16D								---					7/16-14				
1 1/4	1 1/4	6143-20-20D	3.25	3.75	2.44	2.625	1.250	1.25	1.16	.53	.38	1.38	-----	1.75	1.750	MK 552	1/2-13 X 3 1/4	222	6.3
		6144-20-20D								---					1/2-13				
1 1/2	1 1/2	6143-24-24D	3.75	4.50	2.96	3.125	1.437	1.50	1.34	.66	.50	1.62	-----	2.00	2.125	MK 553	5/8-11 X 4	225	10.4
		6144-24-24D								---					5/8-11				
2	2	6143-32-32D	4.50	5.25	3.46	3.812	1.750	1.94	1.69	.78	.50	2.00	-----	2.50	2.500	MK 554	3/4-10 X 4 1/2	228	16.9
		6144-32-32D								---					3/4-10				
2 1/2 <sup>⑤</sup>	2 1/2	6143-40-40D	5.50	6.88	4.50	4.875	2.312	2.32	2.12	.94	.50	2.50	-----	3.00	3.000	MK 2557	7/8-9 X 6	232	36.6
		6144-40-40D								---					7/8-9				
3 <sup>⑤</sup>	3	6143-48-48D	6.50	8.50	5.00	6.000	2.812	2.90	2.62	1.19	.50	3.00	-----	3.50	3.625	MK 756	1 1/8-7 X 7	237	59.0
		6144-48-48D								---					1 1/8-7				

① Order Separately    ② 2500 PSI Max    ③ 2000 PSI Max    ④ 500 PSI Max    ⑤ Not included in SAE J518 specifications

MATERIAL : 316L STAINLESS STEEL