

Developers and Manufacturers of Hydraulic Flanges & Components

BUTT WELD ELBOW FLANGES

For Schedule 160 Pipe

SAE BOLT PATTERN										61 SERIES									
FLANGE SIZE	PIPE SIZE	PART NUMBER	A	B	C	D	E	F ₁	F ₂	Gmm	H ₁	H ₂	Jmm	K	L	MOUNTING KIT ^①			WT
																PART NO.	BOLT SIZE	O-RING	
1/2	1/2	6141-08-08DM8	2.00	2.12	1.44	1.500	.688	.53	.47	8.5	.38	.75	----	.88	1.000	MKM 541	M8 x 50	210	1.3
		6142-08-08DM8								---			---						
3/4	3/4	6141-12-12DM10	2.25	2.62	1.70	1.875	.875	.75	.61	10.5	.38	.88	----	1.12	1.250	MKM 542	M10 x 60	214	2.2
		6142-12-12DM10								---			---						
1	1	6141-16-16DM10	2.50	2.82	1.94	2.062	1.031	.94	.81	10.5	.38	1.00	----	1.38	1.562	MKM 543	M10 x 65	219	2.9
		6142-16-16DM10								---			---						
1 1/4	1 1/4	6141-20-20DM10	3.00	3.19	2.40	2.312	1.188	1.25	1.16	10.5	.38	1.25	----	1.75	1.750	MKM 4532	M10 x 75	222	4.8
		6142-20-20DM10								---			---						
1 1/2	1 1/2	6141-24-24DM12	3.25	3.75	2.90	2.750	1.406	1.50	1.34	13.0	.50	1.38	----	2.00	2.125	MKM 4533	M12 x 90	225	7.3
		6142-24-24DM12								---			---						
2	2	6141-32-32DM12	3.75	4.00	3.40	3.062	1.688	1.94	1.69	13.0	.50	1.62	----	2.50	2.500	MKM 4534	M12 x 100	228	9.7
		6142-32-32DM12								---			---						
2 1/2 ^②	2 1/2	6141-40-40DM12	4.50	4.50	3.96	3.500	2.000	2.32	2.12	13.0	.50	2.00	----	3.00	3.000	MKM 4535	M12 x 120	232	15.9
		6142-40-40DM12								---			---						
3 ^③	3	6141-48-48DM16	5.00	5.31	4.96	4.188	2.438	2.90	2.62	17.0	.50	2.25	----	3.50	3.625	MKM 548	M16 x 150	237	23.8
		6142-48-48DM16								---			---						
3 1/2 ^④	3 1/2	6141-56-56DM16	5.50	6.00	5.40	4.750	2.750	3.36	3.00	17.0	.50	2.50	----	4.00	4.109	MKM 549	M16 x 160	241	34.1
		6142-56-56DM16								---			---						
4 ^④	4	6141-64-64DM16	6.00	6.38	5.96	5.125	3.062	3.83	3.44	17.0	.50	2.75	----	4.50	4.609	MKM 550	M16 x 180	245	41.2
		6142-64-64DM16								---			---						
5 ^④	5	6141-80-80DM16	7.50	7.25	6.90	6.000	3.625	4.81	4.31	17.0	.50	3.38	----	5.62	5.609	MKM 1569	M16 x 200	253	60.2
		6142-80-80DM16								---			---						

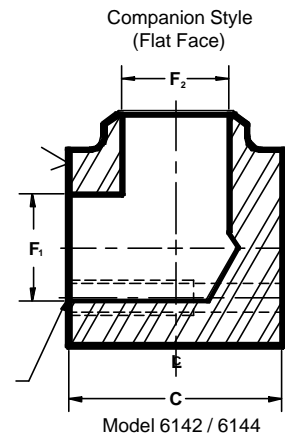
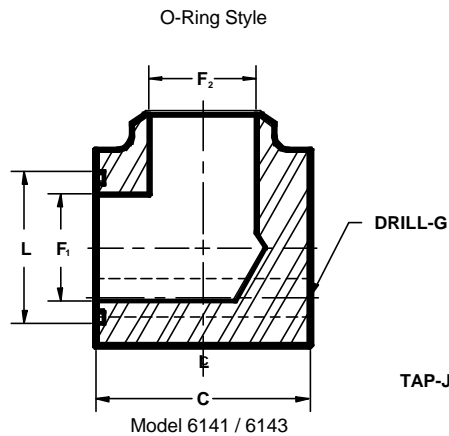
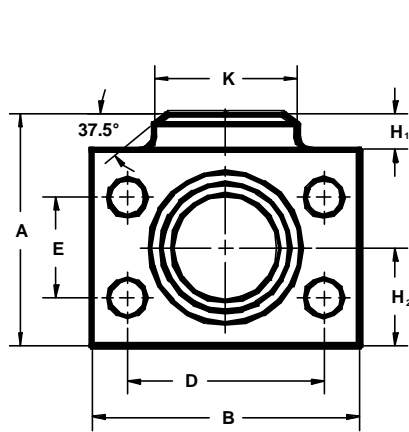

SAE BOLT PATTERN										62 SERIES									
FLANGE SIZE	PIPE SIZE	PART NUMBER	A	B	C	D	E	F ₁	F ₂	Gmm	H ₁	H ₂	Jmm	K	L	MOUNTING KIT ^①			WT
																PART NO.	BOLT SIZE	O-RING	
1/2	1/2	6143-08-08DM8	2.25	2.22	1.46	1.594	.718	.53	.47	8.5	.38	.88	----	.88	1.000	MKM 541	M8 x 50	210	1.6
		6144-08-08DM8								---			---						
3/4	3/4	6143-12-12DM10	2.50	2.81	1.70	2.000	.937	.75	.61	10.5	.38	1.00	----	1.12	1.250	MKM 542	M10 x 60	214	2.6
		6144-12-12DM10								---			---						
1	1	6143-16-16DM12	2.75	3.19	2.21	2.250	1.093	.94	.81	12.5	.38	1.12	----	1.38	1.562	MKM 2533	M12 x 75	219	4.2
		6144-16-16DM12								---			---						
1 1/4	1 1/4	6143-20-20DM12	3.25	3.75	2.44	2.625	1.250	1.25	1.16	13.0	.38	1.38	----	1.75	1.750	MKM 578	M12 x 80	222	6.3
		6144-20-20DM12								---			---						
1 1/2	1 1/2	6143-24-24DM16	3.75	4.50	2.96	3.125	1.437	1.50	1.34	17.0	.50	1.62	----	2.00	2.125	MKM 553	M16 x 100	225	10.4
		6144-24-24DM16								---			---						
2	2	6143-32-32DM20	4.50	5.25	3.46	3.812	1.750	1.94	1.69	21.0	.50	2.00	----	2.50	2.500	MKM 554	M20 x 120	228	16.9
		6144-32-32DM20								---			---						
2 1/2 ^⑤	2 1/2	6143-40-40DM24	5.50	6.88	4.50	4.875	2.312	2.32	2.12	25.5	.50	2.50	----	3.00	3.000	MKM 2557	M24 x 150	232	36.6
		6144-40-40DM24								---			---						
3 ^⑤	3	6143-48-48DM30	6.50	8.50	5.00	6.000	2.812	2.90	2.62	32.0	.50	3.00	----	3.50	3.625	MKM 756	M30 x 180	237	59.0
		6144-48-48DM30								---			---						

① Order Separately ② 2500 PSI Max ③ 2000 PSI Max ④ 500 PSI Max ⑤ Not included in SAE J518 specifications MATERIAL: 316L STAINLESS STEEL
NOTE: DIMENSIONS ARE IN INCHES UNLESS OTHERWISE NOTED. 9/01