

Developers and Manufacturers of Hydraulic Flanges & Components

NPTF THREADED IN-LINE FLANGES

SAE BOLT PATTERN										61 SERIES							
FLANGE SIZE	PIPE SIZE	PART NUMBER	A	B	C	D	E	F	Gmm	H	Jmm	K	L	MOUNTING KIT ^①			WT
														PART NO.	BOLT SIZE	O-RING	
1/2	1/2	6149-08-08DM8	1.50	2.12	1.25	1.500	.688	.50	8.5	1.06	----	1/2	1.000	MKM 519	M8 x 45	210	.8
		---							M8 x 1.25		---						
3/4	3/4	6149-12-12DM10	1.75	2.62	1.25	1.875	.875	.75	10.5	1.06	----	3/4	1.250	MKM 520	M10 x 45	214	1.2
		---							M10 x 1.5		---						
1	1	6149-16-16DM10	2.00	2.82	1.50	2.062	1.031	1.00	10.5	1.25	----	1	1.562	MKM 521	M10 x 50	219	1.7
		---							M10 x 1.5		---						
1 1/4	1 1/4	6149-20-20DM10	2.50	3.19	1.50	2.312	1.188	1.25	10.5	1.31	----	1 1/4	1.750	MKM 3526	M10 x 50	222	2.3
		---							M10 x 1.5		---						
1 1/2	1 1/2	6149-24-24DM12	2.75	3.75	1.75	2.750	1.406	1.50	13.0	1.31	----	1 1/2	2.125	MKM 2565	M12 x 60	225	3.6
		---							M12 x 1.75		---						
2	2	6149-32-32DM12	3.25	4.00	1.75	3.062	1.688	1.94	13.0	1.31	----	2	2.500	MKM 2566	M12 x 60	228	4.2
		---							M12 x 1.75		---						
2 1/2 ^②	2 1/2	6149-40-40DM12	4.00	4.50	2.00	3.500	2.000	2.44	13.0	1.75	----	2 1/2	3.000	MKM 2574	M12 x 70	232	6.5
		---							M12 x 1.75		---						
3 ^③	3	6149-48-48DM16	4.50	5.50	2.25	4.188	2.438	2.94	17.0	2.00	----	3	3.625	MKM 1516	M16 x 80	237	9.8
		---							M16 x 2		---						
3 1/2 ^④	3 1/2	6149-56-56DM16	5.00	6.00	2.25	4.750	2.750	3.44	17.0	1.91	----	3 1/2	4.109	MKM 2576	M16 x 90	241	11.0
		---							M16 x 2		---						
4 ^④	4	6149-64-64DM16	5.50	6.50	2.50	5.125	3.062	3.94	17.0	2.06	----	4	4.609	MKM 2545	M16 x 90	245	14.5
		---							M16 x 2		---						

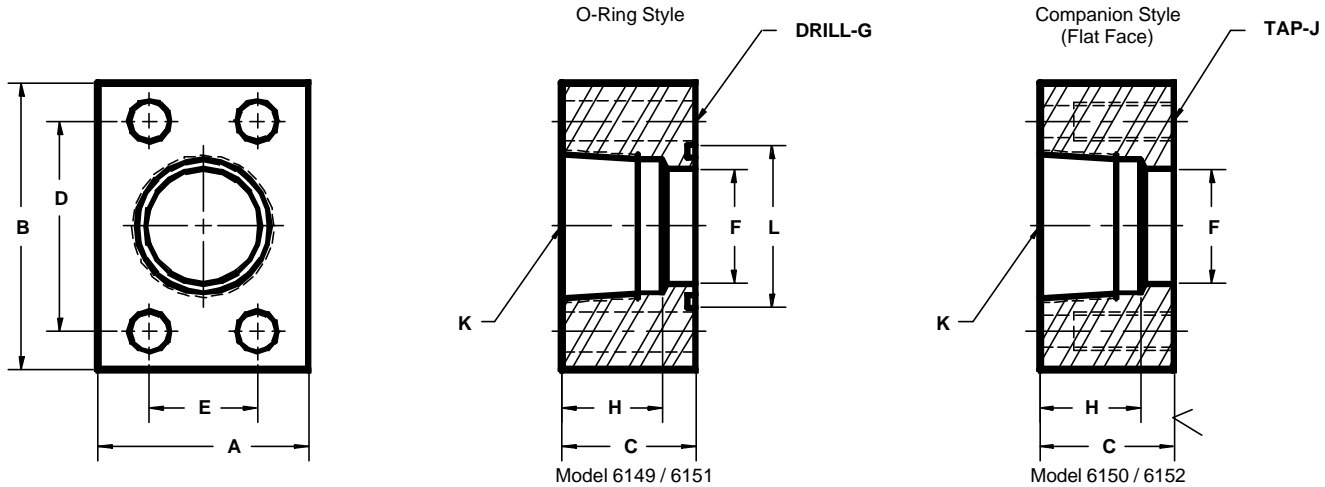

SAE BOLT PATTERN										62 SERIES							
FLANGE SIZE	PIPE SIZE	PART NUMBER	A	B	C	D	E	F	Gmm	H	Jmm	K	L	MOUNTING KIT ^①			WT
														PART NO.	BOLT SIZE	O-RING	
1/2	1/2	6151-08-08DM8	1.75	2.22	1.25	1.594	.718	.50	8.5	1.06	----	1/2	1.000	MKM 519	M8 x 45	210	1.1
		---							M8 x 1.25		---						
3/4	3/4	6151-12-12DM10	2.00	2.81	1.25	2.000	.937	.75	10.5	1.06	----	3/4	1.250	MKM 520	M10 x 45	214	1.5
		---							M10 x 1.5		---						
1	1	6151-16-16DM12	2.25	3.19	1.50	2.250	1.093	1.00	12.5	1.25	----	1	1.562	MKM 525	M12 x 55	219	2.3
		---							M12 x 1.75		---						
1 1/4	1 1/4	6151-20-20DM12	2.75	3.75	1.50	2.625	1.250	1.25	13.0	1.31	----	1 1/4	1.750	MKM 522	M12 x 55	222	3.7
		---							M12 x 1.75		---						
1 1/2	1 1/2	6151-24-24DM16	3.25	4.50	1.75	3.125	1.437	1.50	17.0	1.31	----	1 1/2	2.125	MKM 527	M16 x 65	225	5.6
		---							M16 x 2		---						
2	2	6151-32-32DM20	4.00	5.25	1.75	3.812	1.750	1.94	21.0	1.31	----	2	2.500	MKM 516	M20 x 70	228	7.8
		---							M20 x 2.5		---						
2 1/2 ^⑤	2 1/2	6151-40-40DM24	5.00	6.88	2.00	4.875	2.312	2.44	25.5	1.75	----	2 1/2	3.000	MKM 517	M24 x 80	232	15.1
		---							M24 x 3		---						
3 ^⑤	3	6151-48-48DM30	6.00	8.50	2.50	6.000	2.812	2.94	32.0	2.00	----	3	3.625	MKM 518	M30 x 110	237	27.5
		---							M30 x 3.5		---						

① Order Separately ② 2500 PSI Max ③ 2000 PSI Max ④ 500 PSI Max ⑤ Not included in SAE J518 specifications
NOTE: DIMENSIONS ARE IN INCHES UNLESS OTHERWISE NOTED.

MATERIAL: 316L STAINLESS STEEL
9/01