

Developers and Manufacturers of Hydraulic Flanges & Components

## BUTT WELD IN-LINE PIPE FLANGES

For Schedule XXS Pipe

SAE BOLT PATTERN										61 SERIES			WT
FLANGE SIZE	PIPE SIZE	PART NUMBER	A	B	C	D	E	F	H	MOUNTING KIT <sup>①</sup>			
										PART NO.	BOLT SIZE	O-RING	
1/2	1/2	1121-08-08	1.50	2.12	1.25	1.500	.688	.25	.38	MK 512	5/16-18 X 1 1/2	210	.7
		1122-08-08											
3/4	3/4	1121-12-12	1.75	2.62	1.25	1.875	.875	.44	.38	MK 1525	3/8-16 X 1 1/2	214	1.0
		1122-12-12											
1	1	1121-16-16	2.00	2.82	1.38	2.062	1.031	.60	.50	MK 1542	3/8-16 X 1 1/2	219	1.2
		1122-16-16											
1 1/4	1 1/4	1121-20-20	2.50	3.19	1.38	2.312	1.188	.89	.50	MK 1527	7/16-14 X 1 1/2	222	1.6
		1122-20-20											
1 1/2	1 1/2	1121-24-24	2.75	3.75	1.50	2.750	1.406	1.10	.50	MK 1547	1/2-13 X 1 3/4	225	2.3
		1122-24-24											
2	2	1121-32-32	3.25	4.00	1.75	3.062	1.688	1.50	.75	MK 582	1/2-13 X 1 3/4	228	2.8
		1122-32-32											
2 1/2 <sup>②</sup>	2 1/2	1121-40-40	4.00	4.50	2.00	3.500	2.000	1.77	.75	MK 561	1/2-13 X 2	232	4.8
		1122-40-40											
3 <sup>③</sup>	3	1121-48-48	4.50	5.31	2.25	4.188	2.438	2.30	.75	MK 585	5/8-11 X 2 1/2	237	7.2
		1122-48-48											
3 1/2 <sup>④</sup>	3 1/2	1121-56-56	5.00	6.00	1.75	4.750	2.750	2.73	.75	MK 1571	5/8-11 X 2	241	5.9
		1122-56-56											
4 <sup>④</sup>	4	1121-64-64	5.50	6.38	1.75	5.125	3.062	3.15	.75	MK 1572	5/8-11 X 2	245	6.7
		1122-64-64											
5 <sup>④</sup>	5	1121-80-80	7.00	7.25	2.50	6.000	3.625	4.06	1.00	MK 1573	5/8-11 X 2 1/2	253	14.3
		1122-80-80											

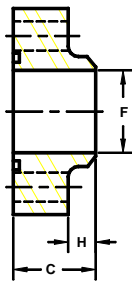

O-RING  
1121  
1123

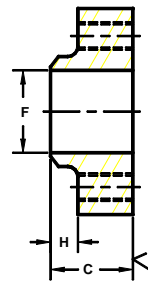
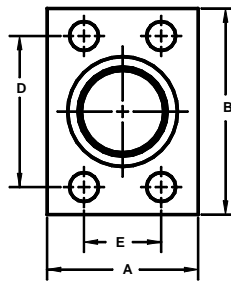

FLAT-FACED  
1122  
1124

SAE BOLT PATTERN										62 SERIES			WT
FLANGE SIZE	PIPE SIZE	PART NUMBER	A	B	C	D	E	F	H	MOUNTING KIT <sup>①</sup>			
										PART NO.	BOLT SIZE	O-RING	
1/2	1/2	1123-08-08	1.75	2.22	1.25	1.594	.718	.25	.38	MK 512	5/16-18 X 1 1/2	210	.8
		1124-08-08											
3/4	3/4	1123-12-12	2.00	2.81	1.25	2.000	.937	.44	.38	MK 1525	3/8-16 X 1 1/2	214	1.3
		1124-12-12											
1	1	1123-16-16	2.25	3.19	1.50	2.250	1.093	.60	.50	MK 1504	7/16-14 X 2	219	1.5
		1124-16-16											
1 1/4	1 1/4	1123-20-20	2.75	3.75	1.50	2.625	1.250	.89	.50	MK 2540	1/2-13 X 2	222	2.1
		1124-20-20											
1 1/2	1 1/2	1123-24-24	3.25	4.50	1.50	3.125	1.437	1.10	.50	MK 562	5/8-11 X 2	225	3.3
		1124-24-24											
2	2	1123-32-32	4.00	5.25	2.00	3.812	1.750	1.50	.75	MK 1548	3/4-10 X 2 1/2	228	5.9
		1124-32-32											
2 1/2 <sup>⑤</sup>	2 1/2	1123-40-40	5.00	6.88	2.50	4.875	2.312	1.77	.75	MK 5535	7/8-9 X 3	232	12.0
		1124-40-40											
3 <sup>⑤</sup>	3	1123-48-48	6.00	8.50	3.00	6.000	2.812	2.30	.88	MK 1776	1 1/8-7 X 4	237	23.3
		1124-48-48											

1. Order Separately. 2. 2500 PSI Max. 3. 2000 PSI Max. 4. 500 PSI Max. 5. Not included in SAE J518

©Copyright March 2006