

JIS B 2291, 210K, SOCKET WELD IN-LINE PIPE FLANGES

TYPE SSA & SSB For American Pipe and JIS O-Ring

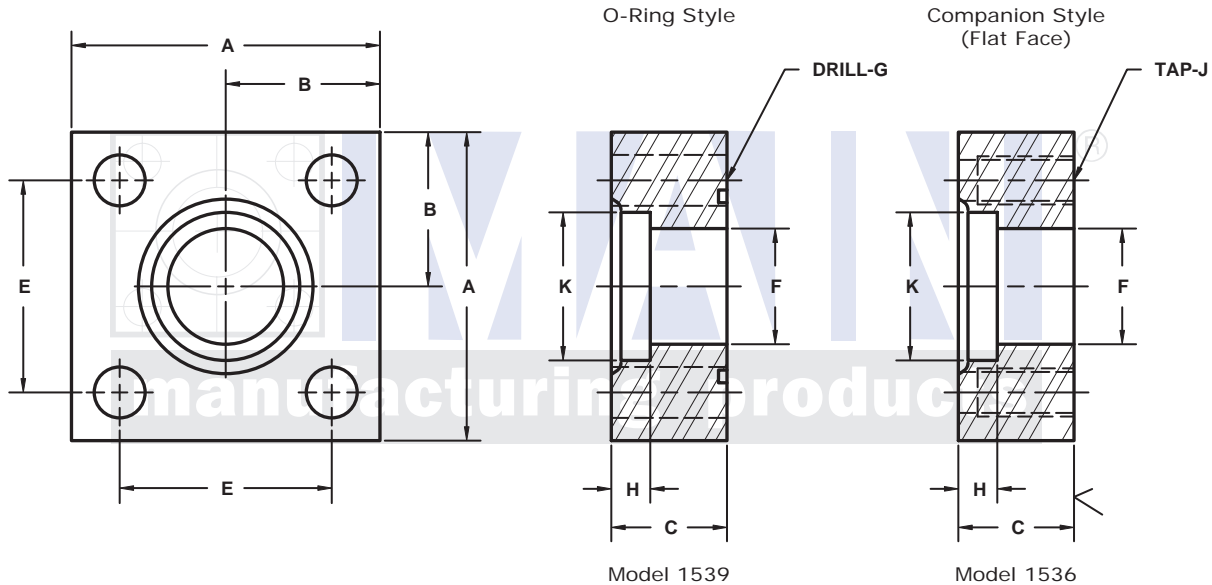

3181 TRI-PARK DR. GRAND BLANC, MI 48439 800-521-7918 810-953-1380 FAX 810-953-1385 INFO@MAINMFG.COM

FLANGE SIZE	PIPE SIZE	PART NUMBER	A	B	C	Emm	E	F	Gmm Jmm	H	K	MOUNTING KIT ^①			WT
												PART NO.	BOLT SIZE	O-RING	
15	15	1539-08-08M	2.25	1.12	.87	36.0	1.417	.63	11.0	.50	.860	MKM 4571	M10 x 40	G25	1.0
		M10x1.5							-----			---			
20	15	1539-12-08M	2.25	1.12	.87	40.0	1.574	.63	11.0	.50	.860	MKM 4572	M10 x 40	G30	1.0
		M10x1.5							-----			---			
20	20	1539-12-12M	2.25	1.12	.87	40.0	1.574	.81	11.0	.50	1.070	MKM 4572	M10 x 40	G30	.9
		M10x1.5							-----			---			
25	20	1539-16-12M	2.75	1.38	1.10	48.0	1.890	.81	13.0	.50	1.070	MKM 4573	M12 x 50	G35	1.8
		M12x1.75							-----			---			
25	25	1539-16-16M	2.75	1.38	1.10	48.0	1.890	.98	13.0	.50	1.335	MKM 4573	M12 x 50	G35	1.7
		M12x1.75							-----			---			
32	25	1539-20-16M	3.00	1.50	1.10	56.0	2.205	.98	13.0	.50	1.335	MKM 4574	M12 x 50	G40	1.6
		M12x1.75							-----			---			
32	32	1539-20-20M	3.00	1.50	1.10	56.0	2.205	1.24	13.0	.50	1.680	MKM 4574	M12 x 50	G40	1.4
		M12x1.75							-----			---			
40	32	1539-24-20M	3.75	1.88	1.38	65.0	2.559	1.24	18.0	.50	1.680	MKM 4575	M16 x 60	G50	4.2
		M16x2							-----			---			
40	40	1539-24-24M	3.75	1.88	1.38	65.0	2.559	1.48	18.0	.62	1.920	MKM 4575	M16 x 60	G50	3.9
		M16x2							-----			---			
50	40	1539-32-24M	4.00	2.00	1.38	73.0	2.874	1.48	18.0	.62	1.920	MKM 4576	M16 x 60	G60	4.5
		M16x2							-----			---			
50	50	1539-32-32M	4.00	2.00	1.38	73.0	2.874	1.87	18.0	.62	2.411	MKM 4576	M16 x 60	G60	4.3
		M16x2							-----			---			
65	50	1539-40-32M	5.00	2.50	1.75	92.0	3.622	1.87	22.0	.62	2.411	MKM 4577	M20 x 75	G75	8.8
		M20x2.5							-----			---			
65	65	1539-40-40M	5.00	2.50	1.75	92.0	3.622	2.36	22.0	.75	2.911	MKM 4577	M20 x 75	G75	8.6
		M20x2.5							-----			---			
80	80	1539-48-48M	5.50	2.75	1.75	103.0	4.055	2.80	24.0	.75	3.540	MKM 4578	M22 x 80	G85	9.5
		M22x2.5							-----			---			

① Order Separately

NOTE: DIMENSIONS ARE IN INCHES UNLESS OTHERWISE NOTED.

© Copyright Main Mfg 2012