

# SAE STRAIGHT THREADED BRANCH TEE FLANGES

SAE BOLT PATTERN										61 SERIES					
FLANGE SIZE	PORT SIZE	PART NUMBER	A	B	C	D	E	F	G	H	K	MOUNTING KIT <sup>Ⓞ</sup>			WT
									J			PART NO.	BOLT SIZE	O-RING	
1/2	-8	1157-08-08	2.50	2.12	1.44	1.500	.688	.50	.34	1.25	3/4-16	MK 541	5/16-18 x 2	210	1.7
		1158-08-08							5/16-18			-----	---		
3/4	-10	1157-12-10	3.00	2.62	1.70	1.875	.875	.50	.41	1.50	7/8-14	MK 542	3/8-16 x 2 1/2	214	3.0
		1158-12-10							3/8-16			-----	---		
3/4	-12	1157-12-12	3.00	2.62	1.70	1.875	.875	.75	.41	1.50	1 1/16-12	MK 542	3/8-16 x 2 1/2	214	2.8
		1158-12-12							3/8-16			-----	---		
1	-14	1157-16-14	4.00	2.82	1.94	2.062	1.031	.75	.41	2.00	1 3/16-12	MK 543	3/8-16 x 2 3/4	219	4.7
		1158-16-14							3/8-16			-----	---		
1	-16	1157-16-16	4.00	2.82	1.94	2.062	1.031	1.00	.41	2.00	1 5/16-12	MK 543	3/8-16 x 2 3/4	219	4.6
		1158-16-16							3/8-16			-----	---		
1 1/4	-20	1157-20-20	4.50	3.19	2.40	2.312	1.188	1.25	.47	2.25	1 5/8-12	MK 578	7/16-14 x 3 1/4	222	7.0
		1158-20-20							7/16-14			-----	---		
1 1/2	-24	1157-24-24	4.50	3.75	2.90	2.750	1.406	1.50	.53	2.25	1 7/8-12	MK 545	1/2-13 x 4	225	9.8
		1158-24-24							1/2-13			-----	---		
2	-32	1157-32-32	5.25	4.00	3.94	3.062	1.688	1.94	.53	2.62	2 1/2-12	MK 592	1/2-13 x 5	228	15.7
		1158-32-32							1/2-13			-----	---		

O-Ring Style

Companion Style (Flat Face)

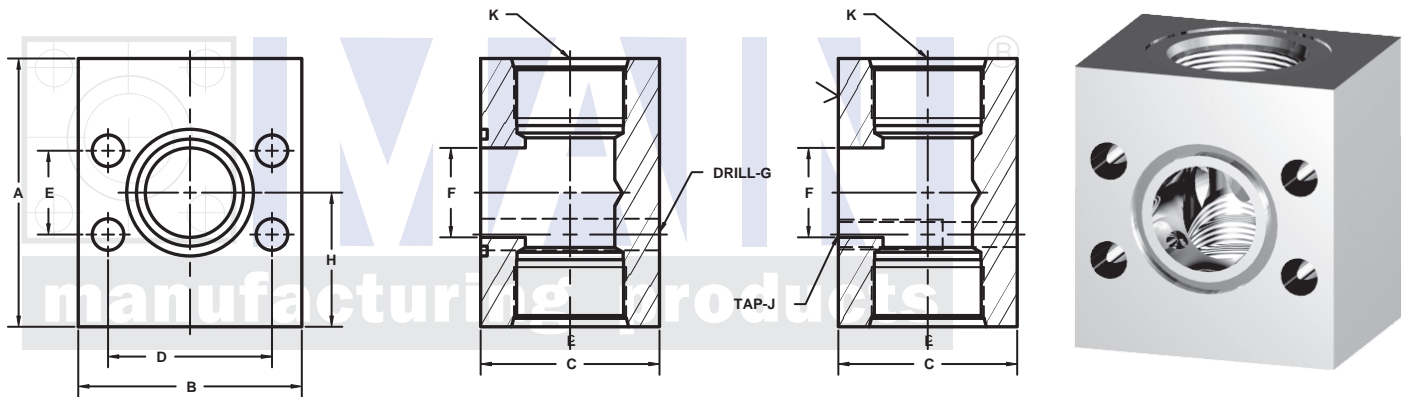

Model 1157 / 1159

Model 1158 / 1160

3181 TRI-PARK DR. GRAND BLANC, MI 48439 800-521-7918 810-953-1380 FAX 810-953-1385 INFO@MAINMFG.COM

SAE BOLT PATTERN										62 SERIES					
FLANGE SIZE	PORT SIZE	PART NUMBER	A	B	C	D	E	F	G	H	K	MOUNTING KIT <sup>Ⓞ</sup>			WT
									J			PART NO.	BOLT SIZE	O-RING	
1/2	-8	1159-08-08	2.50	2.22	1.46	1.594	.718	.50	.34	1.25	3/4-16	MK 541	5/16-18 x 2	210	1.8
		1160-08-08							5/16-18			-----	---		
3/4	-10	1159-12-10	3.00	2.81	1.70	2.000	.937	.50	.41	1.50	7/8-14	MK 542	3/8-16 x 2 1/2	214	3.3
		1160-12-10							3/8-16			-----	---		
3/4	-12	1159-12-12	3.00	2.81	1.70	2.000	.937	.75	.41	1.50	1 1/16-12	MK 542	3/8-16 x 2 1/2	214	3.1
		1160-12-12							3/8-16			-----	---		
1	-14	1159-16-14	4.00	3.19	1.96	2.250	1.093	.75	.47	2.00	1 3/16-12	MK 551	7/16-14 x 2 3/4	219	5.5
		1160-16-14							7/16-14			-----	---		
1	-16	1159-16-16	4.00	3.19	1.96	2.250	1.093	1.00	.47	2.00	1 5/16-12	MK 551	7/16-14 x 2 3/4	219	5.4
		1160-16-16							7/16-14			-----	---		
1 1/4	-20	1159-20-20	4.50	3.75	2.44	2.625	1.250	1.25	.53	2.25	1 5/8-12	MK 552	1/2-13 x 3 1/4	222	9.0
		1160-20-20							1/2-13			-----	---		
1 1/2	-24	1159-24-24	4.50	4.50	2.96	3.125	1.437	1.50	.66	2.25	1 7/8-12	MK 553	5/8-11 x 4	225	12.7
		1160-24-24							5/8-11			-----	---		
2	-32	1159-32-32	6.00	5.25	3.94	3.812	1.750	1.94	.78	3.00	2 1/2-12	MK 1507	3/4-10 x 5	228	25.8
		1160-32-32							3/4-10			-----	---		

Ⓞ Order Separately

**NOTE:** The pressure rating of the assembly should not exceed the lower of the flange pad or the fitting. Check the fitting manufacturer for details.