

SOCKET WELD PIPE IN-LINE FLANGES (Pg 1/2)

WITH 7/16-20 (-4) SAE GAUGE PORT ©

SAE BOLT PATTERN			61 SERIES												
FLANGE SIZE	PIPE SIZE	PART NUMBER	A	B	C	D	E	F	G	H	K	MOUNTING KIT®			WT
									J			PART NO.	SCREW SIZE	O-RING	
1/2	1/2	3101-08-08	1.50	2.12	1.25	1.500	.688	.50	.34	.38	.860	MK 519	5/16-18 x 1 3/4	210	.7
		3102-08-08							5/16-18						
3/4	1/2	3101-12-08	1.75	2.62	1.25	1.875	.875	.50	.41	.38	.860	MK 520	3/8-16 x 2	214	1.3
		3102-12-08							3/8-16						
3/4	3/4	3101-12-12	1.75	2.62	1.25	1.875	.875	.75	.41	.50	1.070	MK 520	3/8-16 x 2	214	1.2
		3102-12-12							3/8-16						
1	3/4	3101-16-12	2.00	2.82	1.25	2.062	1.031	.75	.41	.50	1.070	MK 1501	3/8-16 x 2	219	1.6
		3102-16-12							3/8-16						
1	1	3101-16-16	2.00	2.82	1.25	2.062	1.031	1.00	.41	.50	1.335	MK 1501	3/8-16 x 2	219	1.5
		3102-16-16							3/8-16						
1 1/4	1	3101-20-16	2.50	3.19	1.25	2.312	1.188	1.00	.47	.50	1.335	MK 1502	7/16-14 x 2	222	2.1
		3102-20-16							7/16-14						
1 1/4	1 1/4	3101-20-20	2.50	3.19	1.25	2.312	1.188	1.25	.47	.50	1.680	MK 1502	7/16-14 x 2	222	2.0
		3102-20-20							7/16-14						
1 1/4	1 1/2	-----	3.00	3.19	2.50	2.312	1.188	1.25	---	.50	1.920	-----	-----	---	5.4
		3102-20-24							7/16-14						
1 1/2	1 1/4	3101-24-20	2.75	3.75	1.25	2.750	1.406	1.25	.53	.50	1.680	MK 505	1/2-13 x 2	225	2.8
		3102-24-20							1/2-13						
1 1/2	1 1/2	3101-24-24	2.75	3.75	1.25	2.750	1.406	1.50	.53	.50	1.920	MK 505	1/2-13 x 2	225	2.5
		3102-24-24							1/2-13						
1 1/2	2	-----	3.50	3.75	2.25	2.750	1.406	1.50	---	.50	2.411	-----	-----	---	3.2
		3102-24-32							1/2-13						

MATERIAL:
Low Carbon Steel

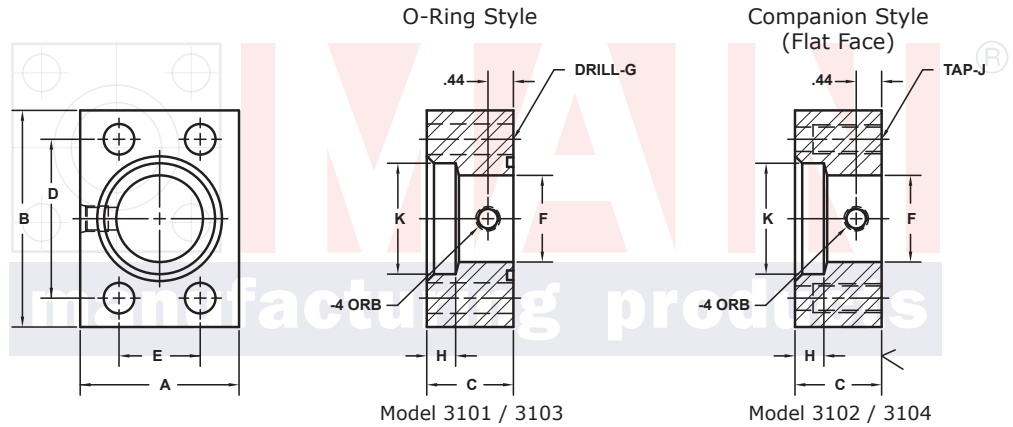
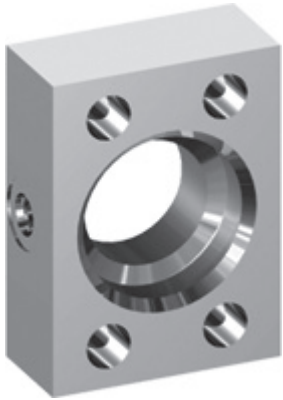

3181 TRI-PARK DR. GRAND BLANC, MI 48439 800-521-7918 810-953-1380 FAX 810-953-1385 INFO@MAINMFG.COM

SAE BOLT PATTERN			62 SERIES												
FLANGE SIZE	PIPE SIZE	PART NUMBER	A	B	C	D	E	F	G	H	K	MOUNTING KIT®			WT
									J			PART NO.	SCREW SIZE	O-RING	
1/2	1/2	3103-08-08	1.75	2.22	1.25	1.594	.718	.50	.34	.50	.860	MK 519	5/16-18 x 1 3/4	210	1.1
		3104-08-08							5/16-18						
3/4	1/2	3103-12-08	2.00	2.81	1.25	2.000	.937	.50	.41	.50	.860	MK 520	3/8-16 x 2	214	1.6
		3104-12-08							3/8-16						
3/4	3/4	3103-12-12	2.00	2.81	1.25	2.000	.937	.75	.41	.50	1.070	MK 520	3/8-16 x 2	214	1.5
		3104-12-12							3/8-16						
1	3/4	3103-16-12	2.25	3.19	1.25	2.250	1.093	.75	.47	.50	1.070	MK 1504	7/16-14 x 2	219	2.1
		3104-16-12							7/16-14						
1	1	3103-16-16	2.25	3.19	1.25	2.250	1.093	1.00	.47	.50	1.335	MK 1504	7/16-14 x 2	219	1.9
		3104-16-16							7/16-14						
1 1/4	1	3103-20-16	2.75	3.75	1.25	2.625	1.250	1.00	.53	.50	1.335	MK 514	1/2-13 x 2	222	2.9
		3104-20-16							1/2-13						
1 1/4	1 1/4	3103-20-20	2.75	3.75	1.25	2.625	1.250	1.25	.53	.50	1.680	MK 514	1/2-13 x 2	222	2.7
		3104-20-20							1/2-13						
1 1/4	1 1/2	-----	3.00	3.75	2.00	2.625	1.250	1.25	---	.50	1.920	-----	-----	---	5.1
		3104-20-24							1/2-13						

① Order Separately

© Also available with 1/4" NPTF or 9/16-18 (-6) SAE GAUGE PORT

SOCKET WELD PIPE IN-LINE FLANGES (Pg 2/2)

WITH 7/16-20 (-4) SAE GAUGE PORT ⑥

SAE BOLT PATTERN										61 SERIES					
FLANGE SIZE	PIPE SIZE	PART NUMBER	A	B	C	D	E	F	G J	H	K	MOUNTING KIT①			WT
												PART NO.	SCREW SIZE	O-RING	
2	1 1/4	3101-32-20	3.25	4.00	1.50	3.062	1.688	1.25	.53	.50	1.680	MK 506	1/2-13 x 2 1/4	228	4.5
		3102-32-20							1/2-13						
2	1 1/2	3101-32-24	3.25	4.00	1.50	3.062	1.688	1.50	.53	.50	1.920	MK 506	1/2-13 x 2 1/4	228	4.3
		3102-32-24							1/2-13						
2	2	3101-32-32	3.25	4.00	1.50	3.062	1.688	1.94	.53	.62	2.411	MK 506	1/2-13 x 2 1/4	228	3.6
		3102-32-32							1/2-13						
2 1/2 ^②	2	3101-40-32	4.00	4.50	1.75	3.500	2.000	1.94	.53	.62	2.411	MK 507	1/2-13 x 2 1/2	232	6.8
		3102-40-32							1/2-13						
2 1/2 ^②	2 1/2	3101-40-40	4.00	4.50	1.75	3.500	2.000	2.44	.53	.75	2.911	MK 507	1/2-13 x 2 1/2	232	5.7
		3102-40-40							1/2-13						
3 ^③	2 1/2	3101-48-40	4.50	5.31	2.00	4.188	2.438	2.44	.66	.75	2.911	MK 508	5/8-11 x 3	237	9.7
		3102-48-40							5/8-11						
3 ^③	3	3101-48-48	4.50	5.31	2.00	4.188	2.438	2.94	.66	.75	3.540	MK 508	5/8-11 x 3	237	8.3
		3102-48-48							5/8-11						
3 1/2 ^④	3	3101-56-48	5.00	6.00	1.50	4.750	2.750	2.94	.66	.75	3.540	MK 509	5/8-11 x 2 1/2	241	8.5
		3102-56-48							5/8-11						
3 1/2 ^④	3 1/2	3101-56-56	5.00	6.00	1.50	4.750	2.750	3.44	.66	.75	4.045	MK 509	5/8-11 x 2 1/2	241	7.5
		3102-56-56							5/8-11						
4 ^④	4	3101-64-64	5.50	6.38	1.50	5.125	3.062	3.94	.66	.75	4.550	MK 510	5/8-11 x 2 1/2	245	8.3
		3102-64-64							5/8-11						
5 ^④	5	3101-80-80	7.00	7.25	2.00	6.000	3.625	4.94	.66	.75	5.635	MK 511	5/8-11 x 3	253	16.0
		3102-80-80							5/8-11						

MATERIAL:
Low Carbon Steel

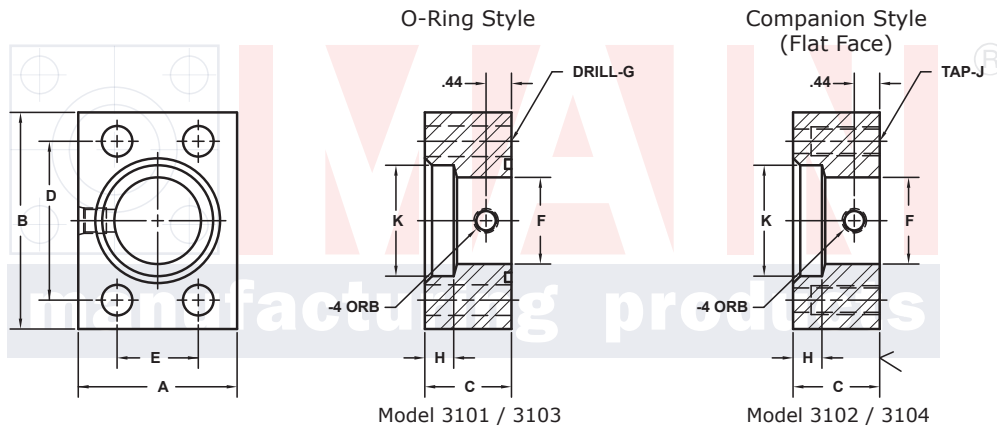

Model 3101 / 3103

Model 3102 / 3104

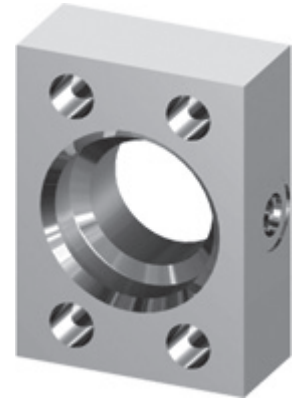

3181 TRI-PARK DR. GRAND BLANC, MI 48439 800-521-7918 810-953-1380 FAX 810-953-1385 INFO@MAINMFG.COM

SAE BOLT PATTERN										62 SERIES					
FLANGE SIZE	PIPE SIZE	PART NUMBER	A	B	C	D	E	F	G J	H	K	MOUNTING KIT①			WT
												PART NO.	SCREW SIZE	O-RING	
1 1/2	1 1/4	3103-24-20	3.25	4.50	1.50	3.125	1.437	1.25	.66	.50	1.680	MK 515	5/8-11 x 2 1/2	225	5.1
		3104-24-20							5/8-11						
1 1/2	1 1/2	3103-24-24	3.25	4.50	1.50	3.125	1.437	1.50	.66	.50	1.920	MK 515	5/8-11 x 2 1/2	225	4.8
		3104-24-24							5/8-11						
1 1/2	2	-----	4.00	4.50	3.00	3.125	1.437	1.50	---	.62	2.411	-----	-----	---	12.6
		3104-24-32							5/8-11						
2	1 1/2	3103-32-24	4.00	5.25	1.75	3.812	1.750	1.50	.78	.50	1.920	MK 516	3/4-10 x 3	228	8.5
		3104-32-24							3/4-10						
2	2	3103-32-32	4.00	5.25	1.75	3.812	1.750	1.94	.78	.62	2.411	MK 516	3/4-10 x 3	228	7.8
		3104-32-32							3/4-10						
2 1/2	2	3103-40-32	5.00	6.88	2.00	4.875	2.312	1.94	.94	.62	2.411	MK 517	7/8-9 x 3 1/2	232	15.7
		3104-40-32							7/8-9						
2 1/2	2 1/2	3103-40-40	5.00	6.88	2.00	4.875	2.312	2.44	.94	.62	2.911	MK 517	7/8-9 x 3 1/2	232	15.2
		3104-40-40							7/8-9						
3	3	3103-48-48	6.00	8.50	2.50	6.000	2.812	2.94	1.19	.62	3.540	MK 718	1 1/8-7 x 4 1/2	237	28.0
		3104-48-48							1 1/8-7						

① Order Separately ② 2500 PSI Max ③ 2000 PSI Max ④ 500 PSI Max
⑥ Also available with 1/4" NPTF or 9/16-18 (-6) SAE GAUGE PORT