

SOCKET WELD TUBE IN-LINE FLANGES (Pg 1/2)

SAE BOLT PATTERN			61 SERIES													
FLANGE SIZE	TUBE SIZE	PART NUMBER	A	B	C	D	E	F	G		H	K	MOUNTING KIT®			WT
									J				PART NO.	SCREW SIZE	O-RING	
1/2	3/8	1113-08-06	1.50	2.12	.75	1.500	.688	.31	.34	.38	.385		MK 501	5/16-18 x 1 1/4	210	.6
		1114-08-06							5/16-18							
1/2	1/2	1113-08-08	1.50	2.12	.75	1.500	.688	.31	.34	.38	.510		MK 501	5/16-18 x 1 1/4	210	.6
		1114-08-08							5/16-18							
1/2	5/8	1113-08-10	1.50	2.12	.75	1.500	.688	.50	.34	.38	.635		MK 501	5/16-18 x 1 1/4	210	.5
		1114-08-10							5/16-18							
1/2	3/4	1113-08-12	1.50	2.12	.75	1.500	.688	.50	.34	.38	.760		MK 501	5/16-18 x 1 1/4	210	.5
		1114-08-12							5/16-18							
3/4	1/2	1113-12-08	1.75	2.62	1.00	1.875	.875	.31	.41	.38	.510		MK 502	3/8-16 x 1 3/4	214	1.1
		1114-12-08							3/8-16							
3/4	3/4	1113-12-12	1.75	2.62	1.00	1.875	.875	.50	.41	.38	.760		MK 502	3/8-16 x 1 3/4	214	1.1
		1114-12-12							3/8-16							
3/4	7/8	1113-12-14	1.75	2.62	1.00	1.875	.875	.75	.41	.50	.885		MK 502	3/8-16 x 1 3/4	214	1.0
		1114-12-14							3/8-16							
3/4	1	1113-12-16	1.75	2.62	1.00	1.875	.875	.75	.41	.50	1.010		MK 502	3/8-16 x 1 3/4	214	1.0
		1114-12-16							3/8-16							
1	3/4	1113-16-12	2.00	2.82	1.00	2.062	1.031	.50	.41	.38	.760		MK 503	3/8-16 x 1 3/4	219	1.4
		1114-16-12							3/8-16							
1	1	1113-16-16	2.00	2.82	1.00	2.062	1.031	.75	.41	.50	1.010		MK 503	3/8-16 x 1 3/4	219	1.3
		1114-16-16							3/8-16							
1	1 1/4	1113-16-20	2.00	2.82	1.00	2.062	1.031	1.00	.41	.50	1.260		MK 503	3/8-16 x 1 3/4	219	1.2
		1114-16-20							3/8-16							

MATERIAL:
Low Carbon Steel

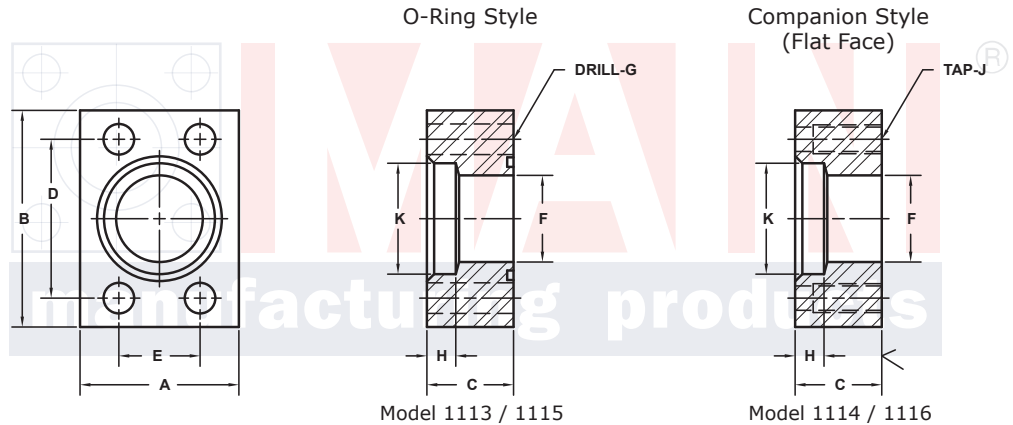
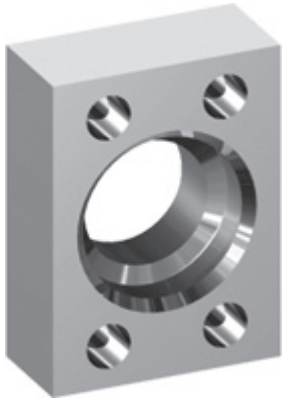

3181 TRI-PARK DR. GRAND BLANC, MI 48439 800-521-7918 810-953-1380 FAX 810-953-1385 INFO@MAINMFG.COM

SAE BOLT PATTERN			62 SERIES													
FLANGE SIZE	TUBE SIZE	PART NUMBER	A	B	C	D	E	F	G		H	K	MOUNTING KIT®			WT
									J				PART NO.	SCREW SIZE	O-RING	
1/2	3/8	1115-08-06	1.75	2.22	1.00	1.594	.718	.31	.34	.50	.385		MK 512	5/16-18 x 1 1/2	210	.9
		1116-08-06							5/16-18							
1/2	1/2	1115-08-08	1.75	2.22	1.00	1.594	.718	.31	.34	.50	.510		MK 512	5/16-18 x 1 1/2	210	.9
		1116-08-08							5/16-18							
1/2	3/4	1115-08-12	1.75	2.22	1.00	1.594	.718	.50	.34	.50	.760		MK 512	5/16-18 x 1 1/2	210	.8
		1116-08-12							5/16-18							
3/4	3/4	1115-12-12	2.00	2.81	1.00	2.000	.937	.50	.41	.50	.760		MK 502	3/8-16 x 1 3/4	214	1.4
		1116-12-12							3/8-16							
3/4	7/8	1115-12-14	2.00	2.81	1.00	2.000	.937	.75	.41	.50	.885		MK 502	3/8-16 x 1 3/4	214	1.4
		1116-12-14							3/8-16							
3/4	1	1115-12-16	2.00	2.81	1.00	2.000	.937	.75	.41	.50	1.010		MK 502	3/8-16 x 1 3/4	214	1.3
		1116-12-16							3/8-16							
1	1	1115-16-16	2.25	3.19	1.00	2.250	1.093	.75	.47	.50	1.010		MK 513	7/16-14 x 1 3/4	219	1.6
		1116-16-16							7/16-14							
1	1 1/4	1115-16-20	2.25	3.19	1.00	2.250	1.093	1.00	.47	.50	1.260		MK 513	7/16-14 x 1 3/4	219	1.5
		1116-16-20							7/16-14							

① Order Separately

SOCKET WELD TUBE IN-LINE FLANGES (Pg 2/2)

SAE BOLT PATTERN										61 SERIES					
FLANGE SIZE	TUBE SIZE	PART NUMBER	A	B	C	D	E	F	G J	H	K	MOUNTING KIT®			WT
												PART NO.	SCREW SIZE	O-RING	
1 1/4	1	1113-20-16	2.50	3.19	1.00	2.312	1.188	.75	.47	.50	1.010	MK 504	7/16-14 x 1 3/4	222	1.9
		1114-20-16							7/16-14			-----	---		
1 1/4	1 1/4	1113-20-20	2.50	3.19	1.00	2.312	1.188	1.00	.47	.50	1.260	MK 504	7/16-14 x 1 3/4	222	1.7
		1114-20-20							7/16-14			-----	---		
1 1/4	1 1/2	1113-20-24	2.50	3.19	1.00	2.312	1.188	1.25	.47	.50	1.510	MK 504	7/16-14 x 1 3/4	222	1.6
		1114-20-24							7/16-14			-----	---		
1 1/2	1 1/4	1113-24-20	2.75	3.75	1.25	2.750	1.406	1.00	.53	.50	1.260	MK 505	1/2-13 x 2	225	3.0
		1114-24-20							1/2-13			-----	---		
1 1/2	1 1/2	1113-24-24	2.75	3.75	1.25	2.750	1.406	1.25	.53	.50	1.510	MK 505	1/2-13 x 2	225	2.8
		1114-24-24							1/2-13			-----	---		
1 1/2	1 3/4	1113-24-28	2.75	3.75	1.25	2.750	1.406	1.50	.53	.50	1.760	MK 505	1/2-13 x 2	225	2.6
		1114-24-28							1/2-13			-----	---		
1 1/2	2	1113-24-32	2.75	3.75	1.25	2.750	1.406	1.50	.53	.50	2.010	MK 505	1/2-13 x 2	225	2.5
		1114-24-32							1/2-13			-----	---		
2	1 1/2	1113-32-24	3.25	4.00	1.50	3.062	1.688	1.25	.53	.50	1.510	MK 506	1/2-13 x 2 1/4	228	4.5
		1114-32-24							1/2-13			-----	---		
2	1 3/4	1113-32-28	3.25	4.00	1.50	3.062	1.688	1.50	.53	.50	1.760	MK 506	1/2-13 x 2 1/4	228	4.3
		1114-32-28							1/2-13			-----	---		
2	2	1113-32-32	3.25	4.00	1.50	3.062	1.688	1.50	.53	.50	2.010	MK 506	1/2-13 x 2 1/4	228	4.1
		1114-32-32							1/2-13			-----	---		
2	2 1/4	1113-32-36	3.25	4.00	1.50	3.062	1.688	1.94	.53	.62	2.260	MK 506	1/2-13 x 2 1/4	228	3.7
		1114-32-36							1/2-13			-----	---		

MATERIAL:
Low Carbon Steel

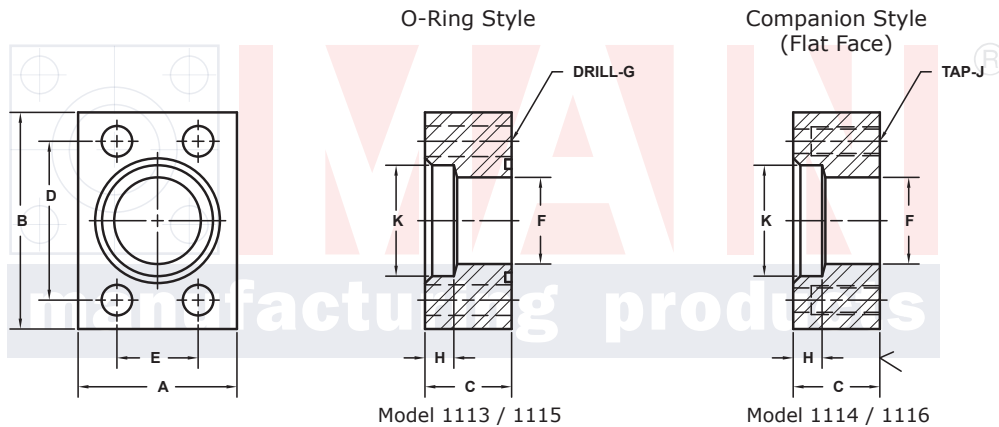

Model 1113 / 1115

Model 1114 / 1116

3181 TRI-PARK DR. GRAND BLANC, MI 48439 800-521-7918 810-953-1380 FAX 810-953-1385 INFO@MAINMFG.COM

SAE BOLT PATTERN										62 SERIES					
FLANGE SIZE	TUBE SIZE	PART NUMBER	A	B	C	D	E	F	G J	H	K	MOUNTING KIT®			WT
												PART NO.	SCREW SIZE	O-RING	
1 1/4	1	1115-20-16	2.75	3.75	1.25	2.625	1.250	.75	.53	.50	1.010	MK 514	1/2-13 x 2	222	3.1
		1116-20-16							1/2-13			-----	---		
1 1/4	1 1/4	1115-20-20	2.75	3.75	1.25	2.625	1.250	1.00	.53	.50	1.260	MK 514	1/2-13 x 2	222	3.0
		1116-20-20							1/2-13			-----	---		
1 1/4	1 1/2	1115-20-24	2.75	3.75	1.25	2.625	1.250	1.25	.53	.50	1.510	MK 514	1/2-13 x 2	222	2.8
		1116-20-24							1/2-13			-----	---		
1 1/2	1 1/2	1115-24-24	3.25	4.50	1.50	3.125	1.437	1.25	.66	.50	1.510	MK 515	5/8-11 x 2 1/2	225	5.0
		1116-24-24							5/8-11			-----	---		
1 1/2	1 3/4	1115-24-28	3.25	4.50	1.50	3.125	1.437	1.50	.66	.50	1.760	MK 515	5/8-11 x 2 1/2	225	4.8
		1116-24-28							5/8-11			-----	---		
1 1/2	2	1115-24-32	3.25	4.50	1.50	3.125	1.437	1.50	.66	.50	2.010	MK 515	5/8-11 x 2 1/2	225	4.7
		1116-24-32							5/8-11			-----	---		
2	2	1115-32-32	4.00	5.25	1.75	3.812	1.750	1.50	.78	.50	2.010	MK 516	3/4-10 x 3	228	8.3
		1116-32-32							3/4-10			-----	---		
2	2 1/4	1115-32-36	4.00	5.25	1.75	3.812	1.750	1.94	.78	.62	2.260	MK 516	3/4-10 x 3	228	7.8
		1116-32-36							3/4-10			-----	---		

① Order Separately